

DESIGN MODULE

FOR

CO-TREATMENT OF FAECAL SLUDGE AND SEPTAGE WITH SEWAGE IN SEWAGE TREATMENT PLANT



PART B: LEARNING NOTES

TITLE

Co-Treatment of Faecal Sludge and Septage with Sewage in Sewage Treatment Plant – (Part B: Learning notes)

PUBLISHER

National Institute of Urban Affairs, Delhi

RESEARCH PROJECT

SANITATION CAPACITY BUILDING PLATFORM

GRAPHIC DESIGN

Deep Pahwa, Devender Singh Rawat, Bhavnesh Bhanot, Preeti Shukla

Copyright @ NIUA (2021)

Year of Publishing 2021

CONTENT

The module has been developed with the collaborative effort of NFSSMA partner organisations under Training Module Review Committee (TMRC) anchored by NIUA.

Editor	Authors	Contributor and reviewer
National Institute of Urban Affairs (NIUA)	National Institute of Urban Affairs Ecosan Services Foundation	National Faecal Sludge and Septage Management Alliance (NFSSMA)

DISCLAIMER

While every effort has been made to ensure the correctness of data/information used in this training module, neither the authors nor NIUA accept any legal liability for the accuracy or inferences drawn from the material contained therein or for any consequences arising from the use of this material. No part of this module may be reproduced in any form (electronic or mechanical) without proper acknowledgement.



Copyright 2021 National Institute of Urban Affairs. This work is licensed under Attribution-ShareAlike 4.0 International. To view a copy of this license, visit <http://creativecommons.org/licenses/by-sa/4.0/>

CONTACT

National Institute of Urban Affairs
1st and 2nd floor Core 4B,
India Habitat Centre,
Lodhi Road, New Delhi 110003, India
Website: www.niua.org, scbp.niua.org
E-Mail: scbp@niua.org

DESIGN MODULE FOR CO-TREATMENT OF FAECAL SLUDGE AND SEPTAGE WITH SEWAGE IN SEWAGE TREATMENT PLANT

PART B: LEARNING NOTES

Collaborative effort under Training Module Review Committee (TMRC)



About National Faecal sludge and Septage Management Alliance (NFSSMA)

The 'NFSSM Alliance' was formed with a vision to "Create an enabling environment which amplifies scaling of safe, sustainable and inclusive FSSM through knowledge, partnerships and innovative solutions by 2024".

Convened by Bill and Melinda Gates Foundation in 2016, the Alliance is a voluntary body that aims to:

- A. Build consensus and drive the discourse on FSSM at a policy level, and
- B. Promote peer learning among members to achieve synergies for scaled implementation and reduce duplication of efforts.

The Alliance currently comprises 32 organizations across the country working towards solutions for Indian states and cities. The Alliance works in close collaboration with the Ministry of Housing and Urban Affairs (MoHUA) and several state and city governments through its members to support the progress and derive actions towards mainstreaming of FSSM at state and national level. The NFSSM Alliance works on all aspects of city sanitation plans to regulatory and institutional frameworks across the sanitation value chain. The NFSSM Alliance working in collaboration with the Ministry of Housing and Urban Affairs has been instrumental in the 'drafting of India's Policy on FSSM launched in 2017. This resulted in 19 out of 36 states and UTs adopting guidelines and policies for FSSM in India.

The strength of the Alliance lies in its diverse membership, which includes research institutes, academic institutions, think-tanks, quasi-government bodies, implementing organizations, data experts, consultants, and intermediaries. This enables a multi-disciplinary view of urban sanitation, with members building on each other's expertise. The Alliance has had enormous success in championing FSSM as a viable solution to the Government of India by broadly focussing on:

1. Influencing and informing policy.
2. Demonstrating success through innovation and pilots.
3. Building capacities of key stakeholders across the value chain.

The collaborative continues to work towards promoting the FSSM agenda through policy recommendations and sharing best practices which are inclusive, comprehensive, and have buy-in from several stakeholders in the sector.

About Training Module Review Committee (TMRC)

To ensure quality control in content and delivery of trainings and capacity building efforts, a **Training Module Review Committee (TMRC)** was formed with the collaborative effort of all Alliance partners. TMRC which is **anchored by National Institute of Urban Affairs (NIUA)**, has the following broad objectives:

- A. Identification of priority stakeholders and accordingly training modules for Capacity Building.
- B. Development of a Normative Framework – For Capacity Building at State Level.
- C. Standardization of priority training modules – appropriate standardization of content with flexibility for customization based on State context.
- D. Quality Control of Trainings – criteria for ensuring minimum quality of training content and delivery.
- E. Strategy for measuring impact of trainings and capacity building efforts.

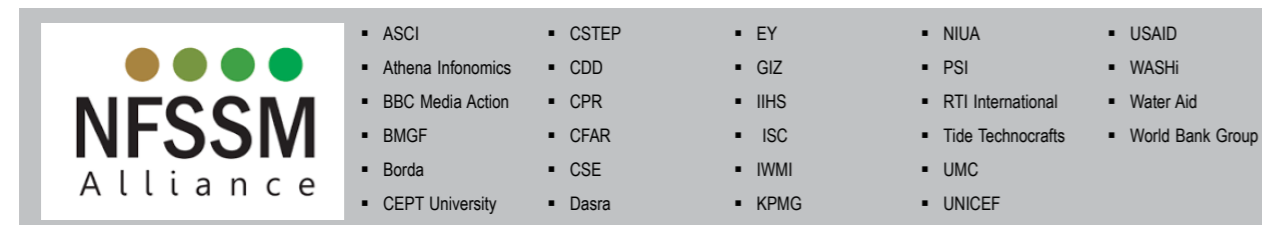

About the Training Module

Title	Co-Treatment of Faecal Sludge and Septage with Sewage in Sewage Treatment Plant (Part B: Learning notes)
Purpose	This module gives the participants hands-on knowledge about designing a co-treatment system including assessment of existing STP capacities and available treatment technology options. With the announcement of SBM-U 2.0 and AMRUT 2.0, continuation of NMCG and the recommendations of the 15th Finance Commission, this module provides participants a detailed understanding for adopting co-treatment, which is a key component under septage management in these national missions.
Target Audience	Officials with engineering background and professional experience in wastewater and septage management such as technical faculties from nodal training institutes, technical officials/ engineers from state govt, parastatal bodies and ULBs; consultants from TSU/PMUs and sector partners.
Learning Objectives	The module aims to convey the following learnings: <ul style="list-style-type: none"> • Understand the working principles of Sewage Treatment Plant • Understand how to conduct feasibility assessment of existing sewage treatment plants (STPs) to evaluate co-treatment potential and quantify the amount of FSS that can be co-treated • Know the approaches for adding faecal sludge in a STP for co-treatment along with the design of additional components such as septage receiving station • Gain insight into the operation and maintenance as well as mitigation measures for different treatment units in a STP
Structure of the Module	The training module is based on case methodology where in the sessions will be combined with exercises based on real-life cases. This helps to trainees to apply the knowledge grasped during the session and reinforce it further. The module is divided into three parts: Part A: This contains the slides used during the session in the presentation format. Part B: This is a comprehensive compilation of the all the session briefs and further reading material which helps to strengthen the learning. Part C: This contains the exercise developed for training based on the real-life cases.
Duration	In this face-to-face training format, this training is conceptualized for two days without site visits and can be adopted for including the site visits depending upon the city where it is being conducted.

LIST OF FIGURES

Figure 1:	Bar diagram shows growth of urban population 1901-2021	4
Figure 2:	Population distribution in India.....	5
Figure 3:	Sewage scenario of India	6
Figure 4:	Key principles to deliver CWIS	11
Figure 5:	Scoring of Swachh Survekshan 2021	22
Figure 6:	Stages of FSSM planning at city level.....	30
Figure 7:	Factors behind creating an enabling environment.....	32
Figure 8:	Different treatment approaches in FSSM.....	33
Figure 9:	Faecal sludge and septage treatment stages and objectives.....	36
Figure 10:	Planning for co-treatment	38
Figure 11:	Graph showing the actual sewage flow and the unutilised capacity of a STP including lead times, design capacity and over-built capacity	38
Figure 12:	Faecal sludge being emptied at a FSTP	46
Figure 13:	Septage being emptied at a FSTP.....	46
Figure 14:	Flow diagram for a centralised sewage treatment plant.....	52
Figure 15:	Flow diagram of decentralised sewage treatment plant.....	53
Figure 16:	Different wastewater treatment processes	54
Figure 17:	Schematic diagram of a mechanised bar screen.....	55
Figure 18:	Schematic diagram of circular grit chamber	56
Figure 19:	Schematic diagram of aerated grit chamber.....	57
Figure 20:	Schematic diagram of primary clarifier	58
Figure 21:	Schematic diagram of DEWATS.....	59
Figure 22:	Schematic diagram of a waste stabilisation pond (WSP)	60
Figure 23:	Schematic diagram of a SBT system.....	61
Figure 24:	Schematic diagram of ASP	62
Figure 25:	Schematic diagram of SBR	63
Figure 26:	Schematic diagram of an activated sludge process having a moving bed biofilm reactor; MBBR media used to provide extra surface for biological growth of aerobic microorganisms	64
Figure 27:	Schematic diagram of MBR.....	65
Figure 28:	Chlorination basin (left); a schematic diagram of chlorine dosing with mixer (right)	65
Figure 29:	Schematic diagram of ozonation.....	66
Figure 30:	Schematic diagram of UV disinfection system.....	67
Figure 31:	Points of FSS addition in a typical wastewater treatment plant	68
Figure 32:	Diurnal curve - volume of sewage v/s. organic load	77
Figure 33:	Layout of a dumping station.....	84
Figure 34:	Design Criteria for Bar Screens.....	85
Figure 35:	Picture of prefabricated manual screen	85
Figure 36:	Picture of a prefabricated mechanical screen.....	86
Figure 37:	Schematic flow diagram (left) and picture (right) of a parabolic grit chamber	87
Figure 38:	Integrated pre-treatment module	88

Figure 39:	Activated carbon filter for odour control	89
Figure 40:	Pre-treatment at headworks of STP	90
Figure 41:	Pre-treatment before equalisation.	90
Figure 42:	Pre-treatment after equalisation.	91
Figure 43:	Schematic diagram of a settling thickening tank	92
Figure 44:	Schematic diagram of a screw press	93
Figure 45:	Schematic diagram of a belt press.....	94
Figure 46:	Schematic diagram of a primary clarifier	100
Figure 47:	Schematic diagram of activated sludge process	102
Figure 48:	Schematic representation of secondary clarifier with main components.	103
Figure 49:	Chlorination basin (left) and schematic diagram of chlorine dosing with mixer (right)	104
Figure 50:	Example of tube settler media for retrofitting secondary clarifier.....	106
Figure 51:	Schematic representation of static flow mixers	107
Figure 52:	Gravity thickener	112
Figure 53:	Schematic diagram of a high rate anaerobic digester.....	113
Figure 54:	Centrifuge dewatering equipment	114
Figure 55:	Points of septage addition in a typical STP	115
Figure 56:	Schematic diagram of co-composting process.....	122
Figure 57:	Typical schematic of solar drying house for sludge treatment	123
Figure 58:	Schematic diagram of a rotary drum dryer (Source: www.benenv.com).....	124
Figure 59:	Schematic diagram of a belt dryer.....	125
Figure 60:	Schematic diagram of a paddle dryer	125
Figure 61:	Schematic of a fluidised bed dryer	126
Figure 62:	Fluidised bed incinerator.....	127
Figure 66:	Schematic diagram of pyrolizer.....	128
Figure 67:	Hydro-thermal carbonisation	129

LIST OF TABLES

Table 1:	Comparative Statistics on the Inventory for the years 2014 and 2020	7
Table 2	Key comparisons across the MDGs and SDG 6.....	12
Table 3:	Physical characteristics of domestic sewage.....	44
Table 4:	Chemical characteristics of domestic sewage.....	44
Table 5:	Biological characteristics of domestic sewage.....	45
Table 6:	Characteristics of faecal sludge, septage and sewage.....	47
Table 7:	Design criteria for screens.....	56
Table 8:	Characteristics of the STP where co-treatment is being proposed	74
Table 9:	Characteristics and future prospect of the catchment of STP.....	74
Table 10:	Characteristics and future prospect of the incoming FSS to be co-treated at the STP	74
Table 11:	Design criteria for horizontal type grit chamber	87
Table 12:	Design criteria for an aerated type parabolic grit chamber	88
Table 13:	Factors leading to instability of the anaerobic digester and mitigation measures.....	116
Table 14:	Operational problems and mitigation measures for mechanised dewatering	116

AGENDA

Duration (Hours)	Session Title
Day 1	
09:30 – 09:45	Registration
09:45 – 10:00	Introduction- Round of Introduction; Setting ground rules; Understanding expectations, aims & objectives
10:00 – 10:45	Context for co-treatment in India and relevant Policies and Programmes
10:45 – 11:20	Approaches for Faecal Sludge and Septage Treatment
11:20 – 11:30	Tea and Coffee Break
11:30 – 12:30	Characterisation of Liquid Waste: Faecal Sludge, Septage and Sewage
12:30 – 13:30	Sewage treatment plant and co-treatment
13:30 – 14:30	Lunch Break
14:30 – 14:45	Exercise: Forming treatment chain at the sewage treatment plant
14:45 - 15:30	Planning of Co-treatment of Sludge and Sewage
15:30 – 15:45	Tea and Coffee Break
15:45 – 16:15	Exercise: Pre-feasibility check for co-treatment of faecal sludge and septage with sewage
16:15 – 17:00	Septage receiving station

Duration (Hours)	Session Title
Day 2	
09:30 – 10:15	Recap, Feedback & Quiz
10:15 – 11:15	Co-treatment in liquid stream at STP
11:15 – 11:30	Tea and Coffee Break
11:30 – 12:15	Exercise: Check for primary and secondary units of the activated sludge process (ASP) system for co-treatment
12:15 – 13:15	Co-treatment in solid stream at STP
13:15 – 14:15	Lunch Break
14:15 – 15:00	Exercise: Check for thickening, digestion treatment units of the ASP system for co-treatment
15:00 - 16:00	Disinfection of sludge
15:00 – 16:15	Tea and Coffee Break
16:15 – 16:45	Videos and exercise: Disinfection of sludge
16:45 – 17:30	Feedback and wrap-up session

Contents

About National Faecal sludge and Septage Management Alliance (NFSSMA)	vi
About Training Module Review Committee (TMRC)	vii
About the Training Module	ix
Agenda	xv
1. Setting the context for co-treatment in India	1
2. National Missions and Programs	15
3. Approaches for faecal sludge and septage treatment	27
4. Characterisation of liquid waste products: faecal sludge, septage, and sewage	43
5. Sewage treatment plant and co-treatment	49
6. Planning for co-treatment of faecal sludge and septage with sewage	73
7. Septage receiving station	81
8. Co-treatment in liquid stream at STP	97
9. Co-treatment in sludge stream at STP	111
10. Disinfection of sludge	121

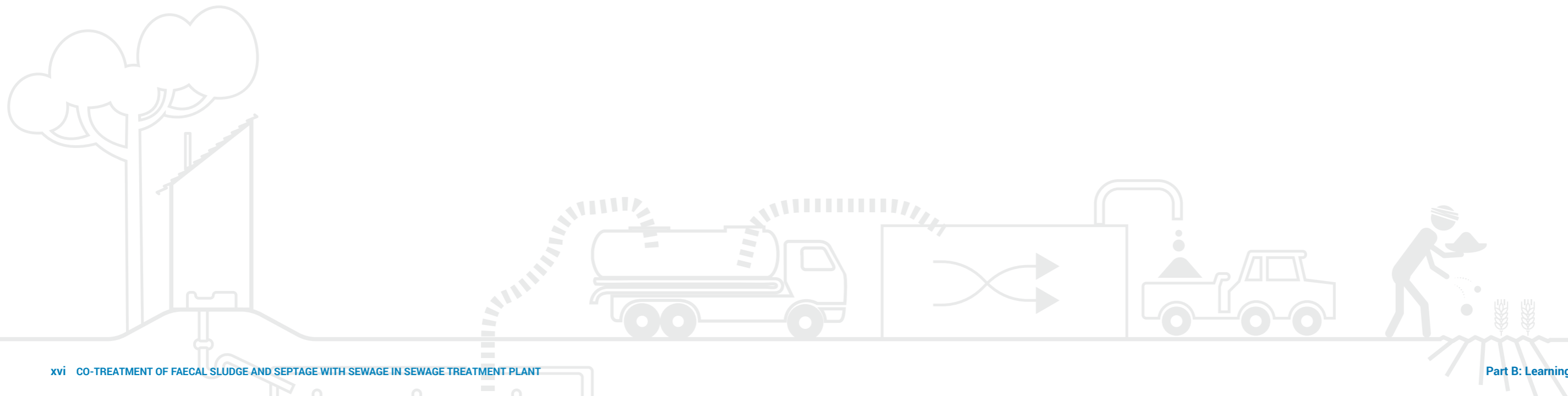

Session

01

Setting the context for co-treatment in India

1. Setting the context for co-treatment in India

1.1 Session objectives

- To understand urbanization and the sanitation challenges associated with it in Indian cities
- To understand the need for co-treatment and its relevance in India
- To learn how the adoption of co-treatment helps in achieving Citywide Inclusive Sanitation (CWIS).

1.2 Session plan

Duration- 30 minutes

Topics	Time	Material/Method
Urbanization and sanitation situation in India	10 min	Powerpoint presentation / Discussion
Relevance of co-treatment in India	5 min	Powerpoint presentation / Discussion
Relation between co-treatment and CWIS approach	5 min	Powerpoint presentation
Achieving SDG 6s through co-treatment	5 Min	Powerpoint presentation
Q&A	5 min	Discussion

1.3 Key facts

- By 2030, an approximate of 60% of the world's population will be residing in the urban centres of the developing countries.
- Increasing urban population puts the national government and ULBs under tremendous pressure.
- With more than 60% of urban households' dependent on onsite sanitation, FSSM has emerged as a viable and incremental approach to cater to urban sanitation challenges in small towns and cities of India.
- FSSM through co-treatment in an STP is a feasible solution to restrict the indiscriminate discharge of highly contaminated faecal sludge and septage into rivers and surrounding environment and aims towards inclusive sanitation to all.

1.4 Learning notes

1.4.1 Urbanization and Sanitation situation in India

About 377 million i.e., 1/3rd of the country lives in urban settlements. Indian urbanization has continued as a part and product of economic change in the past few decades. According to census 2001, 28 % of the population of India was living in urban settlements. It is estimated that by 2045 India is expected to have more than 50% of its population living in urban area, with multiple cities having population more than 10 million persons. The pace at which these urban centers are experiencing population explosion, it is difficult to develop and deploy infrastructure to provide basic municipal services to the residents of the cities (India Urban Conference 2011).

Figure 1: Bar diagram shows growth of urban population 1901-2021(E) (Source - National Inventory of Sewage Treatment Plants, CPCB Report March 2021)

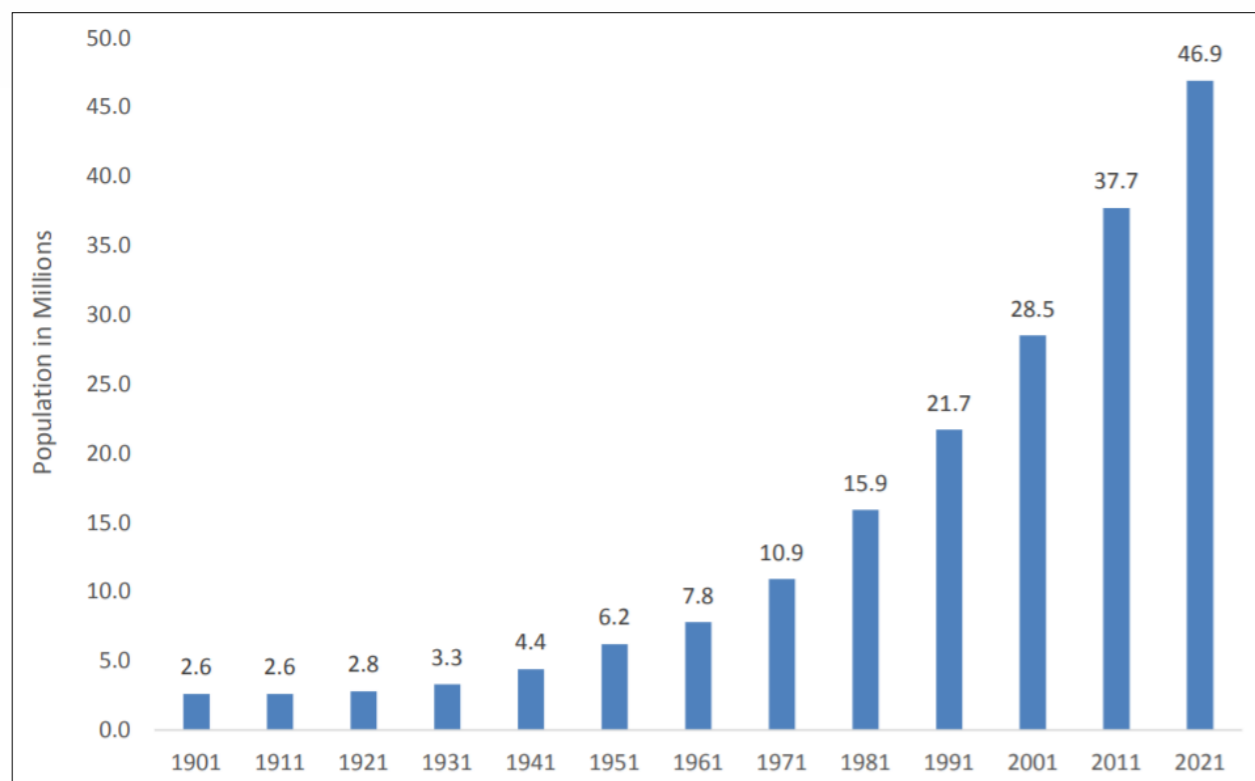

Urbanisation world-wide phenomenon and it is neither unique nor exclusive when it comes to India. It is very important to understand nature i.e., the shape and pattern of urban growth. The distribution of the population in the various class of towns have changed significantly. As per the paper on Urbanization by K. C. Siva Ramakrishnan and B. N. Singh published by Niti Ayog, in 1991, there were 3768 towns and approximately population was equally distributed among the 23 metropolitan cities, 277 class I cities and in the remaining 3468 towns. However, in 2001, there were 4368 towns and approximately 38% of the total urban population resided 35 metro cities, 30.6% in the remaining 358 class I cities and 3975 towns. The analysis of urbanization pattern and projections for the next 20 years indicates that the bulk of the urban population will be living in metropolitan regions and the growth will be seen on the periphery of the large metro cities.

Figure 2: Population distribution in India (Source: Analysis Census of India by IHS)

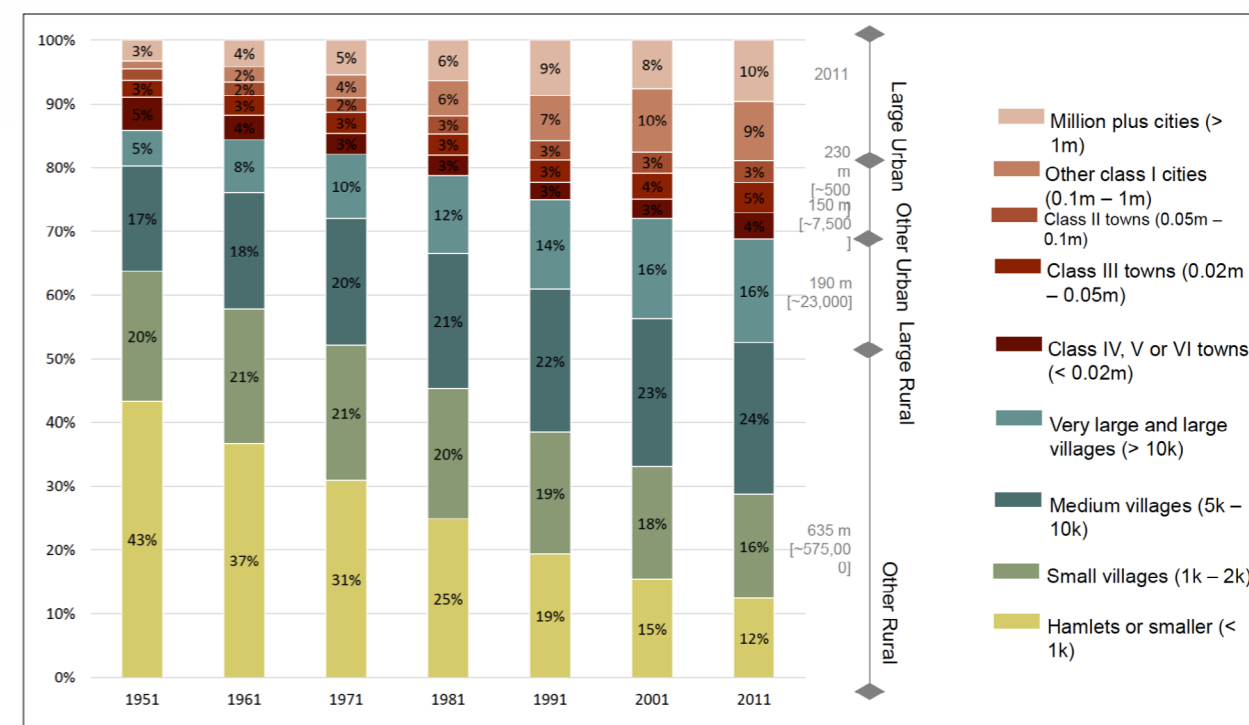

A growing number of rural settlements are emerging as urban (also called as rurban). The delimitation of the boundaries of large cities is done the town planning department to accommodate the partially urbanized villages on its periphery. Due to this, there is a reduction in the agricultural farmlands and occupational patterns of the villagers are changing. Another phenomenon worth noticing is that the large cities are becoming saturated and accumulation of population is observed in the second-tier cities.

After the 2011 census of India, there was a notable demographic shift towards urban centres. In the period from 2001-11 the population growth in the urban India was slightly higher than the rural India. The United Nation, highlights that India's urban population size will nearly double between 2018 and 2050, from 461 to 877 million. The National Commission on Population in India has predicted that in the next 15 years i.e., by 2036, up to 40% of Indians will live in urban areas. The prevailing trends suggest that India is on a steady path of urbanization (Aijaz R.; 2021).

There will be tremendous impact of all this growth on space, environment and quality of life. The urban environment, particularly in large cities, is deteriorating rapidly. The reasons being the rate of provision of infrastructural facilities required to support such large concentration of population is lagging far behind the rate of urbanization. All cities have severe shortage of basic environmental services whose level, quality and distribution have been poor and unequal. Poor and unequal distribution of sanitation services have resulted into serious health impacts particularly affecting the urban poor.

In recent years, the urban environment has become a major subject of concern; among the major environmental problems faced by urban areas are air, water, and soil pollution and growing volume of wastes including hazardous waste. The metro cities are experiencing critical environmental degradation and pushing to the limit their ability to sustain human life. Although the entire urban population is affected, the urban poor are the most vulnerable. It is poor performance of local governments in the delivery of basic urban services that lead to environmental degradation and lower quality of life in urban areas.

“More Indians have mobile phones than toilets”. This news first made headlines in 2010 in both Indian and international media and has since been featured in the media with striking regularity. The government has launched a program – Swachh Bharat Mission (SBM), including a public campaign around environmental sanitation and cleanliness. Sanitation appears finally to be getting the attention it deserves. But it is imperative that urban India needs to address not just toilets but the full cycle of sanitation if it wishes to meet the environmental and public health challenges.

Urban sanitation in India faces many challenges. Many urban areas lack access to improved sanitation arrangements, and nearly two-thirds of wastewater is let out untreated into the environment, polluting land and water bodies. To respond to these environmental and public health challenges, urban India will need to address the full cycle of sanitation, i.e., universal access to toilets, with safe collection, conveyance and treatment of human excreta. In the absence of adequate sanitation, interventions that improve water or hygiene are less effective than they would be if sanitation were improved. The urban poor suffer disproportionately from the lack of adequate sanitation.

The growth of cities into metropolitan cities exerts pressure on water resources in two ways: (a) the increasing need for water to meet the domestic requirements and (b) impact of resultant wastewater discharge on the receiving waters have a cumulative effect in deteriorating quality of receiving water.

In different regions of urban centres, wastewater is let out untreated due to the lack/unavailability of sewerage network and discharged into the natural drainage system causing pollution in downstream areas. An estimated 72% of Indians still lack access to improved sanitation facilities (Ganesh S Kumar et.al., 2011).

Clearly there is a need to emphasize on creating infrastructure for collection, conveyance and proper disposal of the wastewater (Wankhede K.; 2015).

Figure 3: Sewage scenario of India (Source - National Inventory of Sewage Treatment Plants, CPCB Report March 2021)

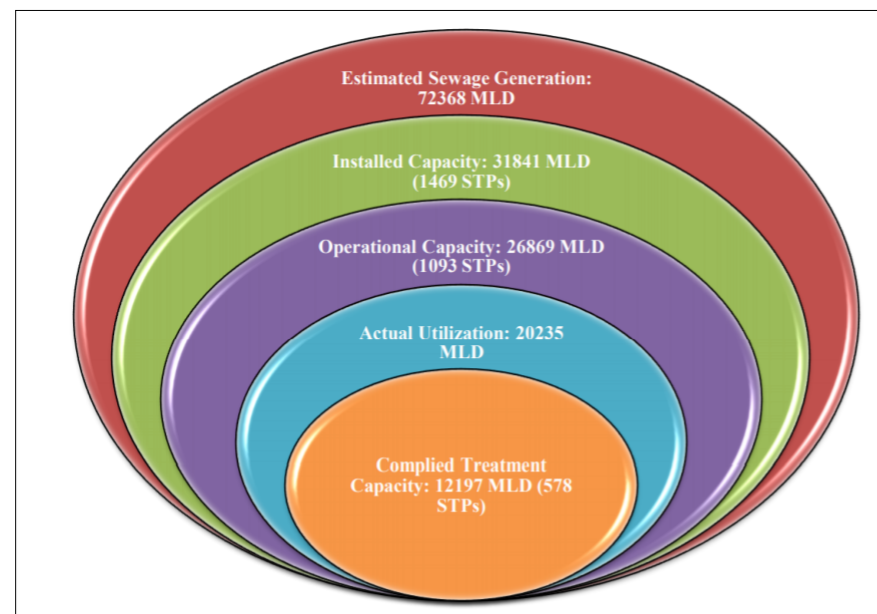

The National Inventory of the Sewage Treatment Plants in India published by Central Pollution Control Board in 2021 gives an overview of the sewerage scenario in the country. The sewage generation from urban centres is estimated as 72,368 MLD. There are 1631 STPs (including proposed STPs) with a total capacity of 36,668 MLD covering 35 States/UTs. Out of 1,631 STPs, 1,093 STPs are operational, 102 are Non-operational, 274 are under construction and 162 STPs are proposed for construction. The actual utilized capacity is 20,235 MLD (27.9 %). This is due to lack of infrastructure for collection and conveyance system in the form of sewers. In many cities, the STP is constructed, and the laying of sewers is incomplete. In many cities sewers have been implemented; however, the household connections are not achieved at the expected rate. Due to this, the gap between the treatment capacity installed and total wastewater generated is increasing at a faster rate as seen in the Figure 3.

The report also shares a comparison of STPs between 2014 and 2020 and states that sewage treatment capacity has enhanced by 50%. Comparative statistics pertaining to the years 2014 and 2020 are presented in Table 1.

Table 1: Comparative Statistics on the Inventory for the years 2014 and 2020 (Source- National Inventory of Sewage Treatment Plants March 2021, CPCB)

Sr. No.	STP Status	2014		2020	
		No s. of STPs	Capacity (MLD)	Nos. of STPs	Capacity (MLD)
1	Operational	522	18883	1093	26869
2	Actual Utilization	-	-	1093	20235
3	Compliance	-	-	578	12197
4	Non-operational	79	1237	102	1406
5	Under Construction	145	2528	274	3566
Total (Sl. No. 1+4+5)		746	22648	1469	31841
6	Proposed	70	628	162	4827

The expansion of sewerage networks in centralized wastewater management approach cannot keep up with city growth, and alternative sanitation systems are needed for Citywide Inclusive Sanitation (CWIS). Based on the Sustainable Development Goals, urban sanitation services should yield safe, equitable, and sustained sanitation outcomes for everyone, prioritizing vulnerable groups. Urban sanitation service expansion, however, has been slow and uneven. The crisis of urban sanitation in India is established by the predominant septic tanks-based sanitation systems that far exceed the coverage of households provided by centralized sewerage-based systems. Centralized networked sanitation systems have been the standard recommended approach for addressing urban wastewater management. However, they lack sustainability due to high capital expenditure (CaPEX) and operating expense (OPEX) apart from huge infrastructure and carbon footprint investment.

Moreover, most investments have been for centralized wastewater treatment and sewerage, which often do not serve newer or informal settlements. Extending such sewer systems to low income and informal settlements can be challenging, costly, and may not be the most suitable and effective for the local context.

As per the report “Solving Urban Challenges with City Wide Inclusive Sanitation” published by the Asian Development Bank in April 2021, there are four categories of challenges in scaling of conventional centralized wastewater management approach:

- Low infrastructure coverage
- Service coverage
- Low service usage
- Weak institutional arrangements

Low Infrastructure Coverage

India is still struggling with wastewater management in the urban cities. Although the cumulative treatment capacity has increased, the real problem has been in collection and conveyance system for wastewater. It may take several decades for sewerage and other sanitation services to become available to all in urban India. In the meantime, the vast majority of urban residents will remain dependent on on-site sanitation facilities such as pour flush toilets discharging to leach pits or septic tanks. Municipal sanitation plans should, therefore, include measures to complete and improve on-site sanitation in order to meet the needs of the city.

The cities should recognize that the worst sanitary conditions are prevalent in poor areas. Construction of a toilet is generally regarded as the householder’s responsibility but, for poor households, investments in sanitation are often constrained by multiple issues such as affordability, land tenure, space constraints and low priority to sanitation.

Therefore, special measures will be required to support service improvements for the poorest sections of the community. The need is to look beyond subsidies and awareness campaigns; and develop technology options that suit the physical conditions in poor neighborhoods.

Limited Access to Services

The statistical numbers and dashboards are not sufficient to provide a full picture regarding access to sanitation services. The existing infrastructure and its allied services are deficient in many ways. Often it is seen that the functionality and upkeep of the sanitation facilities is a challenge due to inappropriate design and construction. Thus, the facilities become inconvenient, unpleasant and unhygienic and soon dysfunctional. This is often the problem with community toilet located in urban slums of large cities. In many cities, the sewerage is laid however, the households are not connected to it. Due to the low affordability of the households, they are not able to pay the sewerage connection charges. Moreover, the households know that once the connection is done, regular payment of taxes will be needed. Currently, due to incomplete onsite sanitation system, the septic effluent and grey water finds its way into the stormwater drains which essentially only relocate the waste to the lowest point in the community of the city. “Out of sight, out of mind!” - Households do not realize the wider impact of unsafe disposal of wastewater.

Low Service Usage

In some places – especially in rural areas or small towns, where toilets are available, they are not used or underused. Household members tend to provide several reasons for not using the toilet. In general, it is seen that households do not like to share the toilets and tend to underuse because they lack the understanding of functioning and maintenance.

For example, in the case of twin-pit pour-flush toilets, some people fear that the pits will fill rapidly if the toilet is used too often; and they may not know that the contents of a full pit can safely be removed manually once they have been given time to degrade. Such problems indicate the need for effective communication in sanitation programs, so that community awareness, preferences, and behaviour are appropriately understood and then addressed through information, advice, and hygiene promotion.

Weak Institutional Arrangements

State agencies and municipalities sometimes make huge investments in sanitation infrastructure, but these do not always deliver their intended benefits. Involvement of multiple agencies during the execution of the project starting with planning, implementation and O&M. Most of the time, the overarching strategy of these different agencies do not align properly and investments are made whenever the funds are available. Responsibilities for different aspects of sanitation are often assigned to many agencies, and coordination between them is not always good. There have been cases, for example, where a state agency has developed a sewage treatment plant even when there are no sewers in the town, then handed it over to a municipality that does not have the technical capacity or financial resources to operate and maintain it. Very less thought is given to the O&M cost of the project and its recovery from the beneficiaries.

Lot of times, the selection of technology for treatment is governed by the company preparing the detailed project report and the engineers of the parastatal bodies or the ULBs. Local conditions and resources are not taken into consideration, because of which the challenges in O&M are faced at a very early stage and the facilities do not function properly. Especially in smaller towns, municipal and line agency staff tend to have limited technical expertise or awareness of the range of non-technical factors that affect the outcome of sanitation investments.

1.4.2 Relevance of Co-treatment

In order to meet the sanitation needs a paradigm shift toward an integrated approach is required. The approach makes maximum use of the current available technologies in order to attain sustainability and meet the environmental and human health targets. In this regard co-treatment of faecal sludge and septage with sewage/solid waste seems a feasible option.

Co-treatment can be simply defined as treatment of different waste products together using existing infrastructure for waste management, for example liquid septage with municipal solid waste, liquid septage and faecal sludge with sewage, or partially stabilized faecal matter with sewage sludge. (Narayana, D 2020)

Our focus here would be co-treating faecal sludge and septage with sewage in a sewage treatment plant (STP).

Why is co-treatment relevant in India? There is an underutilized capacities of sewage treatment plants in our country. Co-treatment will enable the use of these existing treatment plants for treating the faecal sludge and septage. Setting up of a dedicated Faecal Sludge Treatment Plant (FSTP) is a time-consuming affair due to issues such as land identification, clearances and

tendering process. As a result, the need for separate infrastructure and investments for dealing with faecal sludge and septage can be reduced considerably. Another benefit is that the direct discharge of untreated faecal sludge and septage into open environments like rivers, lakes, etc has resulted in severe pollution of our water bodies and related ecosystem. This can be easily prevented through interventions such as co-treatment. Moreover, in case of co-treatment, the existing facilities, site infrastructure and human resource of the STP will be used for co-treatment and thus can eliminate the problem of engaging a new O&M operator and additional cost related to site infrastructure.

According to the 2nd Quarterly report of the Central Monitoring Committee in compliance of the order dated 22.06.2020 (uploaded on 29.06.2020), Secretary, Department of Water Resources, River Development and Ganga Rejuvenation vide his D.O. letter addressed to Chief Secretaries of all States/ UTs has highlighted the issue of adoption of alternate technologies in the form of FSTPs as well as co-treatment of faecal sludge generated from OSS in the city and fringe areas, in the existing STPs. FSTPs, as opposed to conventional sewage treatment plants, are thought to provide various advantages, including lower costs, less reliance on 40 power, shorter construction time, and lower operational costs. As a result, states have been asked to explore implementing FSTPs, as well as co-treatment of faecal sludge in existing STPs, in all towns in their respective states, if practicable, in order to avoid depositing faecal sludge in water bodies/ land and contaminating them.

Co-treatment of FSS provides access to improved sanitation to households, low-income settlements, commercial and institutional establishments of the targeted areas where sewer connections are not feasible or it may take some time to provide the designed service.

Hence, co-existence of Sewerage system with FSSM or until the city is fully covered with sewerage system, in both ways, FSSM through co-treatment is a viable solution.

1.4.3 Relationship between co-treatment and CWIS

Although, sewerage schemes by the city authorities tries to cover each and every household and establishments in the planned areas but it is often observed that some households and establishments are left out from the schemes. Densely populated low-income settlements, sparsely located households and unplanned growth of households are often excluded from the sewerage schemes. Planning of co-treatment of FSS with sewage with the existing plant or upcoming STP can be a viable solution for providing citywide inclusive sanitation. Households who are still dependent on onsite sanitation systems and thus, emptiers who do not have scientific discharge facility for the collected FSS can be benefitted from the co-treatment.

The Citywide Inclusive Sanitation (CWIS) approach has four principles that focuses on different aspects of sanitation management. With regards to co-treatment, there are four principles namely:

- Everyone benefits from safe services and public investment equitably
- Human waste is safely managed along the sanitation chain
- Authorities operate with a clear, inclusive mandate
- Authorities deploy range of hardware, funding and business model which enables adopting simple, local, and financially sustainable technologies that increase the scope of faecal sludge and septage treatment while benefiting all the stakeholders, especially the citizens relying on on-site sanitation systems.

CWIS requires association between stakeholders, which includes national, sub-national and city/municipal governments; utilities and municipal service providers; business and the private sector; civil society, local and international NGOs; donors, bilateral and multilateral agencies and private foundations; as well as academia and dwellers. Each city is unique. Local players need to acknowledge and have shared responsibilities and work collaboratively for providing safe sanitation to all.

Figure 4: Key principles to deliver CWIS (Source: Global Water security and sanitation partnership)



CWIS is an innovative way of sanitation management that focuses on service provision and creating an enabling environment, rather than building sewer networks and wastewater treatment plants. CWIS promotes co-existence of sewerred and non sewerred sanitation in a town with a focus on

reaching to last denominator. Being a public service approach, it helps in establishing safe, equitable and financially viable sanitation services. Thus, ensuring marginalized and vulnerable group can also benefit with sanitation services.

1.4.4 Achieving SDGs through co-treatment

India is also signatory to the '2030 Agenda for Sustainable Development', adopted at the Sustainable Development Summit of the United Nations in September 2015. Out of the seventeen Sustainable Development Goals (SDGs), SDG 6 is directly related to sanitation. The SDG 6 aims to achieve the goal 'Ensure availability and sustainable management of water and sanitation for all'. Especially SDG 6.2 and 6.3 are related to this module on co-treatment of FSSM. In addition to this, there are other SDG 6 like 11 and 12 are related to SDG 6 and target sustainable development of human life through safe, resilient and inclusive development of cities and human settlements.

During the Millennium Development Goals (MDG) time frame (1990 to 2015), the primary investments for urban water and sanitation in urban India were made through the Jawaharlal Nehru National Urban Renewal Mission (JNNURM). While JNNURM prioritized universal coverage, it did not set a target date to achieve this. It did not have any provision for individual toilets, and most of the investments were dedicated to the piecemeal construction of pipes and treatment systems.

The targets for water and sanitation as articulated in Goal 6 of the SDGs mark a substantial move forward from those articulated in the MDGs. 'Water and Sanitation' is a distinct goal in itself, instead of being nested as a target within another goal. SDG 6 moves beyond the singular focus of the MDGs on access (to water and sanitation), and attempts to widen its scope by looking at the entire cycle of water and sanitation. In terms of access, it has set a much more ambitious target of universal access to both water and sanitation.

Table 2 Key comparisons across the MDGs and SDG 6. (Source Operationalizing SDG 6 in Urban India, IIHS 2016)

Sr. No.	Parameter	MDG	SDG
1	Scope	Access to water and sanitation	Access to water and sanitation Improvement in water quality Improvement in water efficiency Integrated water resources management
2	Target	Halve the number of people without access to water and sanitation	Universal Coverage for access to both water and sanitation, i.e., 100% Reducing by half, the proportion of untreated waste water Recycling, improvements in water efficiency (targets not specified)

India's policies have recognized the significance of urban water and sanitation for achieving public health improvements since the 2000s, resulting in a series of significant initiatives for water and sanitation. These initiatives have taken different forms as policies - National Urban Sanitation Policy (2008), programs such as JNNURM, Swachh Bharat Mission (SBM), Atal Mission

for Rejuvenation and Urban Transformation (AMRUT), and other state level programs, Service Level Benchmarking, advisories, guidelines and so on. Water and sanitation have seen increased visibility in public discourse and an increase in budgetary allocations. Urban sanitation has received strong boost from the current national government, the Swachh Bharat Mission (covering both rural and urban areas) being one of the flagship projects (Wankhede K.; 2012).

1.5 Notes for trainer

This session acts as an introduction for understanding the urban sanitation and the different challenges which India face in sanitation sector. It gives information on STP facilities which are up and running in the country and, planning and implementation for co-treatment with relevance in Indian context. The method of co-treatment of FSS with sewage is linked with the components of citywide inclusivity and how this can be of help in achieving SDG 6.

1.6 Bibliography

Ganesh S Kumar, Sitanshu Sekhar Kar, and Animesh Jain (2011), Health and environmental sanitation in India: Issues for prioritizing control strategies, Indian Journal of Occupational and Environmental Medicine.

National Inventory of Sewage Treatment Plants, CPCB, March 2021.

Rumi Aijaz (2021), Managing India's urban transition in 2021, Urban Futures, Observer Research Foundation

Sahana Goswami and Kristina Egge, From Linear to Circular: A Paradigm Shift in Wastewater Management, WRI India, January 2018

Urban sanitation in India: key shifts in the national policy frame - Environment & Urbanization, International Institute for Environment and Development (IIED), 2015.

Wankhade, K (2012), JNNURM: An Opportunity for Sustainable Urbanisation, Indian Institute for human Settlements.

Wankhade, K (2015), Urban sanitation in India: key shifts in the national policy frame, Environment & Urbanization, International Institute for Environmental and Development (IIED)

Wankhade, K (2017), Operationalizing SDG 6 in Urban India, Indian Institute for human Settlements.

NIUA (2020), Co-treatment feasibility (septage with sewage) – Dehradun, Uttarakhand; ADB supported Banjarawala, Mothrawala and Raipur sewerage projects. Under Sanitation Capacity Building Platform, National Institute of Urban Affairs, New Delhi

Narayana, D (2020). Co-treatment of Septage and Faecal Sludge in Sewage Treatment Facilities; A guide for planners and implementers. International Water Association (IWA).

Session

02

National Missions and Programs

2. National Missions and Programs

2.1 Session objectives

- To inform genesis of sanitation policies and programs at national level with focus on non-sewered sanitation
- To understand priorities under various national missions for urban sanitation with focus on co-treatment of faecal sludge and septage with sewage
- To gain knowledge of different policies and guidelines for enabling co-treatment approach in FSSM
- To analyze avenue for funding various aspects of co-treatment under national Missions.

2.2 Session plan

Duration- 15 minutes

Topics	Time	Material/Method
Growing recognition of Faecal Sludge and Septage Management (FSSM) in India	5 min	Powerpoint presentation / Discussion
National Missions and Programs & Advisories and Guidelines related to Sanitation in India	5 min	Powerpoint presentation / Discussion
Q&A	5 min	Discussion

2.3 Key facts

- Under SBM-Urban 2.0, all statutory towns will become at least ODF+; and all cities with <1 lakh population ODF++.
- Under the AMRUT scheme 100% coverage of sewerage and septage in 500 AMRUT cities will be provided with 2.64 crore sewer connections/ septage connections.
- Catering to the needs of the growing urbanization, 15th Finance Commission has recommended a total of Rs.1,21,055 crore for the urban local bodies for the period of 2021-26.

2.4 Learning notes

2.4.1 Growing recognition of Faecal Sludge and Septage Management (FSSM) in India

FSSM is fast gaining traction in India. In 2007, under JNNURM, a guide to decision making sanitation technology options for urban India was launched under which onsite sanitation systems were recognized. In 2010, under the National Urban Policy, rating of 423 Indian cities was done on various sanitation parameters. In 2013, 'The Prohibition of Employment as Manual Scavengers and their Rehabilitation Act' came which focused on safety protocols of sanitation workers. Also, the CPHEEO guidelines were revised from sewerage and sewerage treatment to sludge treatment and septage management and an advisory note on septage management was launched. In 2014, sanitation gained momentum with the launch of Swachh Bharat Mission and AMRUT Mission with funding on septage management by the government. In 2015, the first FSTP was set up in Devanhalli, Karnataka. In 2017, National Policy of Faecal Sludge and Septage Management was launched. In 2018, under the Swachh Survekshan, weightage for onsite system status, collection of septage by ULBs, preparation of FSSM plans and IEC activities were considered. In 2019, MoHUA

launched the SBM ODF+ and ODF++ framework with a focus on conveyance and treatment. An advisory on on-site and off-site sewage management was launched in 2020 thriving the FSSM momentum continuously. In 2021, MoHUA launched the Swachh Bharat Mission (Urban) 2.0 and AMRUT 2.0.

2.4.2 National Programs and Policies

A. Swachh Bharat Mission – Urban (SBM U)

The urban component of the Swachh Bharat Mission was launched in 2014 to eliminate open defecation, eradicate manual scavenging as well as implement modern and scientific SWM, generate awareness about sanitation and its linkages to public health, capacity augmentation for ULBs and to create an enabling environment for private sector participation in projects. The mission was implemented by the Ministry of Housing and Urban Affairs and was supposed to cover 4,041 statutory towns in India till 2019.

Key thrust areas of the mission include:

- Elimination of open defecation
- Eradication of Manual Scavenging by converting insanitary toilets to sanitary
- Modern and Scientific Municipal Solid Waste Management
- Effecting behavioral change regarding healthy sanitation practices
- Awareness generation about sanitation and its linkage with public health
- Capacity Augmentation for ULBs to create an enabling environment for private sector participation

In continuation to SBM(U), the Ministry of Housing and Urban Affairs launched SBM (U) 2.0 in 2021 with a focus on complete faecal sludge and septage management, wastewater treatment, source segregation of garbage, reduction in single use plastic, reduction in air pollution by effectively managing waste from construction and demolition activities, and bioremediation of all legacy dumpsites. At the end of the mission, it is aimed that all statutory towns in India will become ODF+ certified.

Under the SBM-U 2.0 the following objectives are targeted to be achieved:

- a. Sustainable Sanitation and treatment of Wastewater:
 - Holistic Sanitation
 - Eradication of hazardous entry into sewers and septic tanks, and sustaining elimination of manual scavenging
 - Treatment of wastewater before discharge into water bodies, and maximum reuse of wastewater
- b. Sustainable Solid Waste Management
 - Ensuring cleanliness and hygiene in public places
 - Air pollution arising out of SWM activities brought under notified norms of CPCB
 - Phased reduction in use of single-use plastic
- c. Awareness creation along with large scale citizen outreach to create 'Jan Andolan'
- d. Creating Institutional capacity

Under SBM 2.0 envisioned the following outcomes to be achieved:

- All statutory towns will become ODF+ certified.
- All statutory towns with less than 1 lakh population will become ODF++ certified,
- 50% of all statutory towns with less than 1 lakh population will become Water+ certified
- All statutory towns will be at least 3-star Garbage Free rated as per MoHUA's Star Rating Protocol for Garbage Free cities
- Bioremediation of all legacy dumpsites.

It is expected that under Swachh Bharat Mission-Urban 2.0, all statutory towns will become at least ODF+; and all cities with <1 lakh population ODF++. Systems and processes will be in place so that all waste water is safely treated and optimally reused and no untreated wastewater pollutes water bodies.

A financial outlay of Rs. 1,41,600 crores has been finalized for SBM-U 2.0, including central share of Rs. 36,465 for the period 2021-22 to 2025-26 which is over 2.5 times the financial outlay of Rs. 62,009 crores in the last phase of the Mission.

B. Atal Mission for Rejuvenation and Urban Transformation

The Atal Mission for Rejuvenation and Urban Transformation (AMRUT) mission was initiated in June 2015 which aimed to provide basic services (e.g., water supply, sewerage, urban transport) to households and build amenities in cities which will improve the quality of life for all, especially the poor and the disadvantaged is a national priority.

The purpose of AMRUT is to:

- Ensure that every household has access to a tap with the assured supply of water and a sewerage connection.
- Increase the amenity value of cities by developing greenery and well-maintained open spaces (e.g., parks) and
- Reduce pollution by switching to public transport or constructing facilities for non-motorized transport (e.g., walking and cycling). All these outcomes are valued by citizens, particularly women, and indicators and standards have been prescribed by the Ministry of Housing and Urban Affairs in the form of Service Level Benchmarks.

The Priority zone of the Mission is water supply followed by sewerage. The components of the AMRUT consist of capacity building, reform implementation, water supply, sewerage and septage management, storm water drainage, urban transport and development of green spaces and parks. During planning, the Urban Local Bodies (ULBs) will strive to include some smart features in the physical infrastructure components.

AMRUT 2.0

The objective of AMRUT 2.0 is to provide 100% coverage of water supply to all households by providing 2.68 crore urban household tap connections, thereby benefitting around 10.7 crores people. It will provide 100% coverage of sewerage and septage in 500 AMRUT cities, by providing 2.64 crore sewer connections/ septage connections, thereby benefitting around 10.6 crores people. Rejuvenation of water bodies and urban aquifer management will be undertaken to augment sustainable fresh water supply. Recycle and reuse of treated wastewater is expected to cater to 20% of total water needs of the cities and 40% of industrial demand. Under the Mission, fresh water bodies will be protected from getting polluted to make natural resources sustainable.

There will be several defining features of AMRUT-2.0. These include upscaling from 500 cities covered under AMRUT with 1 lakh+ population to all 4,800 cities, covering 100% urban India. It will promote circular economy of water through formulation of City Water Balance Plan (CWBP) for each city, focusing on recycle/reuse of treated sewage, rejuvenation of water bodies and water conservation. Digital economy will be promoted through being a Paperless Mission. Pey Jal Survekshan will be conducted in cities to ascertain equitable distribution of water, reuse of wastewater and mapping of water bodies w.r.t. quantity and quality of water through a challenge process. Technology Sub-Mission for water will leverage latest global technologies in the field of water.

AMRUT2.0 aims to make all the towns 'water secure'. It will build upon the progress of AMRUT to address water needs, rejuvenate water bodies, better manage aquifers, reuse treated wastewater, thereby promoting circular economy of water. The total outlay of AMRUT 2.0 is Rs.2,77,000 crores, including central share of Rs.76,760 crores. This includes Rs.10,000 crores Central share and another Rs.10,000 crores states' share for continuing financial support to AMRUT Mission up to March 2023.

The Mission seeks to promote Aatma Nirbhar Bharat through encouraging Startups and Entrepreneurs. It will lead to promotion of GIG economy and on-boarding of youth & women. Urban Water Information System through NRSC will be developed, leading to Aquifer Management System. Information, Education and Communication campaign will spread awareness among masses about conservation of water. Target based capacity building program will be conducted for all stakeholders including contractors, plumbers, plant operators, students, women and other stakeholders.

Mission has a reform agenda, with focus on strengthening of urban local bodies and water security of the cities. Major reforms include rejuvenation of water bodies, rain water harvesting, reducing Non-Revenue Water (NRW), meeting 40% industrial water demand through recycled used water, dual piping system for bulk users through building bye-laws, unlocking value & improving land use efficiency through proper master planning, improving credit rating & accessing market finance including issuance of municipal bonds and implementation Online Building Permission System under EoDB.

Notification on property tax related to circle rates & increasing periodically, and user charges related to O&M costs is a mandatory reform under AMRUT 2.0. Second instalment of central share will be released only on implementing mandatory reforms. Incentive based reforms will be Rejuvenation of water bodies in cities; Reducing non-revenue water to 20%; Rain water harvesting in all institutional buildings; Reuse of 20% treated waste water; Reuse of waste water to meet 40% industrial water demand; Development of green spaces & parks; Improving credit rating & access to market finance by ULBs; and Improving land use efficiency, through GIS based master planning & efficient town planning

The AMRUT-2.0 Mission will promote Public Private Partnership (PPP). It has been mandated for cities having million plus population to take up PPP projects worth minimum of 10 percent of their total project fund allocation which could be on Annuity/ Hybrid Annuity / BOT Model.

4798 ULBs have already signed the Memorandum of Understanding (MoU) with the Central Government, outlining the role and commitments of all the stakeholders in both the Missions.

C. Smart City Mission

The Smart Cities Mission of the Government was initiated in June 2015 was a bold, new initiative. It is meant to set examples that can be replicated both within and outside the Smart City, catalyzing the creation of similar Smart Cities in various regions and parts of the country. The objective is to promote cities that provide core infrastructure and give a decent quality of life to their citizens, a clean and sustainable environment and application of 'Smart' Solutions. The Smart Cities Mission envisage developing an area within the cities as model areas based on an area development plan by harnessing technology driven, which is anticipated that the effect will be transmitted to other parts of the city, nearby cities and towns.

The Smart Cities Mission is guided by following core principles:

- **Citizens at the core:** Citizens are involved in every stage of Smart City development.
- **More from less:** Smart Cities strive to generate more impact and outcomes from use of less resources- energy, finance and others.
- **Cooperative and competitive federalism:** cooperative collaboration and healthy competition between States and cities.
- **Convergence:** Smart Cities are focused on creating integrated infrastructure and services, promoting circular economy and sustainable habitats through convergence of financial resources and programs.
- **Technology as a means, and not the goal:** Technology enables and provides speed and scale but is not the end result of smart city development.
- **Inclusiveness:** Cities are for all people irrespective of age, gender, background and ability and hence they have to be inclusive to be smart.

D. 15th Finance Commission

To cater to the needs of the growing urbanization needs of the country, the 15th Finance Commission has recommended a total of Rs.1,21,055 crore for the urban local bodies for the period of 2021-26. Among the states and among the ULBs the fund will be primarily be distributed with a weightage of 90% on population and 10% on area.

Funds for Million Plus Cities UAs Fifty urban centres with million plus population have been identified. They consist of forty-four urban agglomerations (excluding Delhi, Chandigarh and Srinagar) and six cities Jaipur, Visakhapatnam, Ludhiana, Faridabad, Vasai- Virar City and Kota. For these cities, during its five-year award period, grants have been recommended to the tune of INR. 38,196 crores in the form of a Million-Plus cities Challenge Fund (MCF). Each urban centre shall have one ULB as a nodal entity which will be made responsible for achieving the performance indicator for the whole UA.

Grants for ULBs (less than Million Plus) The other than Million-Plus cities/towns shall get the grants as per population. Thirty per cent of the total grants to be disbursed to urban local bodies shall be earmarked for sanitation and solid waste management and attainment of star ratings as developed by the MoHUA. In addition, 30 percent of the total grants to be disbursed to urban local bodies shall be earmarked for drinking water, rainwater harvesting and water recycling. However, if any urban local body has fully saturated the needs of one category and there is no requirement of funds for that purpose, it can utilize the funds for the other category.

E. Swachh Survekshan 2021

The Government of India also validated that work done under the flagship program of Swachh Bharat Mission and AMRUT through Swachh Survekshan. Cities are ranked based on GFC star rating, ODF+/ODF++/Water+, also included parameters pertaining to FSSM that helps in monitoring progress made by cities in attaining as well as sustaining ODF and Water Plus status. It also takes into consideration the non-sewered sanitation approach for FSSM as a key parameter to ensure delivery of sanitation services.

Figure 5: Scoring of Swachh Survekshan 2021



(Source: Swachhsurvekshan.org, 2021)

2.4.3 Advisories and guidelines related to sanitation in India

National Policy on Faecal Sludge and Septage management

In 2017, the Ministry of Housing and Urban Affairs recognized that the end objectives and corresponding benefits of SBM cannot be achieved without proper FSSM across the sanitation service chain. Further, it is well understood that sewerage coverage will not meet the complete sanitation needs in all areas of a city, and a strategy that combines onsite and off-site (decentralized and centralized) must co-exist in all cities and must be given equal attention. Over time the relative proportions of coverage by onsite sanitation and off-site systems may change but both will need to be managed well. However, the current policies are not explicit enough and also do not provide an outcome-focused direction on this issue.

The key objective of the urban FSSM Policy is to set the context, priorities, and direction for, and to facilitate, nationwide implementation of FSSM services in all ULBs such that safe and sustainable sanitation becomes a reality for all in each and every household, street, town and city. Only on-site sanitation facilities and areas served by such facilities would fall under the purview of this FSSM Policy. It addresses synergies between FSSM and sewerage systems or municipal solid waste (MSW) management, e.g., co-treatment of faecal sludge and septage at sewage treatment plants or co-treatment and management of faecal sludge and septage, and MSW.

Unless otherwise specified, the scope of this Policy extends to all the projects, programs and schemes of the -Central Government that facilitate and support sanitation services, urban development and improved delivery of services in urban and peri-urban areas of India. It also covers the initiatives undertaken and/or supported by all Central Government Ministries, Departments, Agencies,

Authorities and Public Sector Undertakings that have a bearing on sanitation services in urban and peri-urban areas. Further, the Policy applies to every urban local body, outgrowths in urban agglomerations, census towns as declared by the Registrar General and Census Commissioner of India, notified areas, notified industrial townships, areas under the control of Indian Railways, airports, airbases, ports and harbours, defence establishments, special economic zones, state and central government organizations, places of pilgrimage, religious and historical importance as may be notified by respective State Government from time to time.

SBM Water Plus Protocols:

The purpose of this toolkit is to provide a readiness check and guideline for cities and towns that have already achieved Open Defecation Free (ODF)/ODF+ /ODF++ status as per the existing protocols prescribed by the Ministry of Housing and Urban Affairs (MoHUA) and to work towards ensuring sustainability of sanitation status. This toolkit provides the detailed SBM Water Plus protocol laid down by MoHUA, along with declaration formats to be obtained from various stakeholders, that wards / work circles (in case under jurisdiction of development authority) and cities are required to submit, as part of the SBM Water Plus declaration and certification process

Manuals on sewerage & sewage treatment systems by CPHEEO Manuals:

The manual on sewerage & sewage treatment systems provides a detailed process of the wastewater management, sewerage systems usage and everything related to sewage management spanning over 3 parts of engineering, operation & maintenance and management.

SBM ODF+ & ODF++ Protocol:

This toolkit can serve as a readiness checklist for all ULBs/Development Authorities/ Cantonment Boards to prepare themselves and their concerned stakeholders in achieving either SBM ODF+ and/or SBM ODF++ status and officially declare the same, followed by certification, as per the protocol outlined.

Advisory on onsite & offsite sewage management practices:

This advisory describes the way of integrated planning of sanitation in a city comprising of onsite and off-site sewage management systems. It has identified interventions, as above, for optimal performance of on-site systems and subsequent progressive coverage of on-site systems with off-site systems as and when necessity arises.

Consultative Document on Land Application of Faecal Septage:

This Advisory covers all the key aspects of land application of faecal sludge and septage. It further discusses about the pre-treatment to be given to the faecal septage, precautionary measures to be taken, site selection criteria, dosage and various methods of land application. The monitoring mechanism and record keeping procedures for the land application process are also adequately addressed in the Advisory.

Faecal Sludge and Septage Management- Service Business Models:

This report describes leading practices and innovations identified in Indian context across the FSSM value chain to cover containment, emptying and transport, treatment and safe reuse and disposal. This report has 27 case studies aiming to showcase how faecal sludge is managed, and how to expand services to the millions of people living in thousands of cities in urban India, lacking access to safely managed sanitation.

Advisory on Emergency Response Sanitation Unit:

This advisory describes the technical & managerial interventions for ensuring safety during sewer & septic tank cleaning. It represents an innovative approach to institutionalizing safety practices & putting in place frameworks to mitigate the dangers of this practice.

SOP for Cleaning of Sewers & Septic tanks:

The scope of the SOP is to impart the knowledge into the stakeholders about the cleaning of sewers and emptying of septic tanks before and after the assignment. This document would be found useful by all Urban Local Bodies (ULBs), Public Health Engineering Departments and other agencies engaged in the process of cleaning of sewers / emptying of septic tanks across the country. This slide provides the participants with an overview of different components in both, sewer and non-sewered sanitation systems. In addition to this, it lists down different technologies commonly selected in our cities. More importantly, it outlines the different national missions and programs that have laid down guidelines and provisions for providing safe, effective and efficient.

2.5 Notes for trainer

This session acts as an introduction for understanding the urban sanitation and policies and programs along with the different challenges which India face in sanitation sector. It gives information's on urban sanitation policy and programs in India under government authorities and various funding options for FSSM planning and implementation.

There are no specific case studies, but depending upon the audience examples can be given of how various states have identified and converged funds from different programs.

2.6 Bibliography

MoHUA (2021), Prime Minister launches Schemes for transforming Urban Areas- AMRUT 2.0 and Swachh Bharat Mission-Urban 2.0 [Press Release], Date: 01 October 2021. Link :<https://pib.gov.in/PressReleasePage.aspx?PRID=1760039>

Rumi Aijaz (2021), Managing India's urban transition in 2021, Urban Futures, Observer Research Foundation

Sahana Goswami and Kristina Egge, From Linear to Circular: A Paradigm Shift in Wastewater Management, WRI India, January 2018

Urban sanitation in India: key shifts in the national policy frame - Environment & Urbanization, International Institute for Environment and Development (IIED), 2015.

Wankhade, K (2012), JNNURM: An Opportunity for Sustainable Urbanisation, Indian Institute for human Settlements.

Wankhade, K (2015), Urban sanitation in India: key shifts in the national policy frame, Environment & Urbanization, International Institute for Environmental and Development (IIED)

Wankhade, K (2017), Operationalizing SDG 6 in Urban India, Indian Institute for human Settlements.

2.7 Further Reading

- Kapur, D (2021), Swachh Bharat Mission 2: The pitfalls — and the lure — of centralised urban sanitation system, Down to Earth.
- Declaring your City/Town SBM ODF+ and SBM ODF++ In Toolkit for Urban Local Bodies. New Delhi, India: Ministry of Housing and Urban Affairs, Government of India, 2018.
- Faecal Sludge and Septage Management, An Orientation Module, National Institute of Urban Affairs, New Delhi and UMC, 2018.
- Faecal Sludge and Septage Management — Orientation Module (Part B: Learning Notes), National Institute of Urban Affairs, Delhi and Ecosan Services Foundation, Pune, 2019.
- Faecal Sludge and Septage Management in Urban Areas, Service & Business Models, NITI Aayog, January 2021.
- Financing Faecal Sludge and Septage Management (FSSM) A landscape study of four Indian states, Centre for Water and Sanitation (C-WAS), Centre for Research and Development Foundation (CRDF), CEPT University, June 2019.
- Guidelines for Swachh Bharat Mission – Urban, October 2017.
- National Policy on Faecal Sludge and Septage Management (FSSM), Ministry of Housing and Urban Affairs (MoHUA), Government of India, February 2017.
- Peter Hawkins, Isabel Blackett, and Chris Heymans (2013), Poor-Inclusive Urban Sanitation: An Overview, Water and Sanitation Program.
- Philippe Reymond, Rohit Chandragiri and Lukas Ulrich (2020), Governance Arrangements for the Scaling Up of Small-Scale Wastewater Treatment and Reuse Systems – Lessons from India, Citywide Inclusive Sanitation: The Urban Sustainability Challenge, Frontiers in Environmental Science.
- Sustaining Policy Momentum - Urban Water Supply & Sanitation in India, IIHS RF Paper on Water Supply and Sanitation, 2014.

Session

03

Approaches for faecal sludge and septage treatment

3. Approaches for faecal sludge and septage treatment

3.1 Session objectives

- Revisit the learnings from planning and technology module on faecal sludge and septage management (FSSM)
- Build a foundation for an in-depth understanding of co-treatment of faecal sludge and septage with sewage in sewage treatment plant.

3.2 Session plan

Duration- 45 minutes

Topics	Time	Material/Method
FSSM planning	10 min	Powerpoint presentation / Discussion
FSS treatment	10 min	Powerpoint presentation / Discussion
Rationale for co-treatment at STP	20 min	Powerpoint presentation
Q&A	5 min	Discussion

3.3 Key facts

- Quantification and characterisation of faecal sludge and septage plays a critical role in planning and selection of an appropriate FSSM approach.
- Objective of faecal sludge and septage treatment depends on the treatment standards and use of the treated end products.
- Faecal sludge and septage treatment plant consists of separate treatment chains for solid and liquid treatment.
- Co-treatment of faecal sludge and septage with sewage in an STP provides a holistic solution for managing the Faecal Sludge and Septage (FSS)
- Co-treatment at STP has a very high benefit-to-cost ratio.

3.4 Learning notes

3.4.1 FSSM planning

Planning of faecal sludge and septage management (FSSM) happens across the entire sanitation service chain. The sanitation service chain of non-sewered/hybrid sanitation system consists of containment, emptying, transport, treatment and reuse or disposal of the treated end products. There are three main stages while planning for FSSM at a city scale: (1) quantification and characterisation of sludge, (2) selecting an appropriate approach for treatment and (3) creating an enabling environment.

Figure 6: Stages of FSSM planning at city level

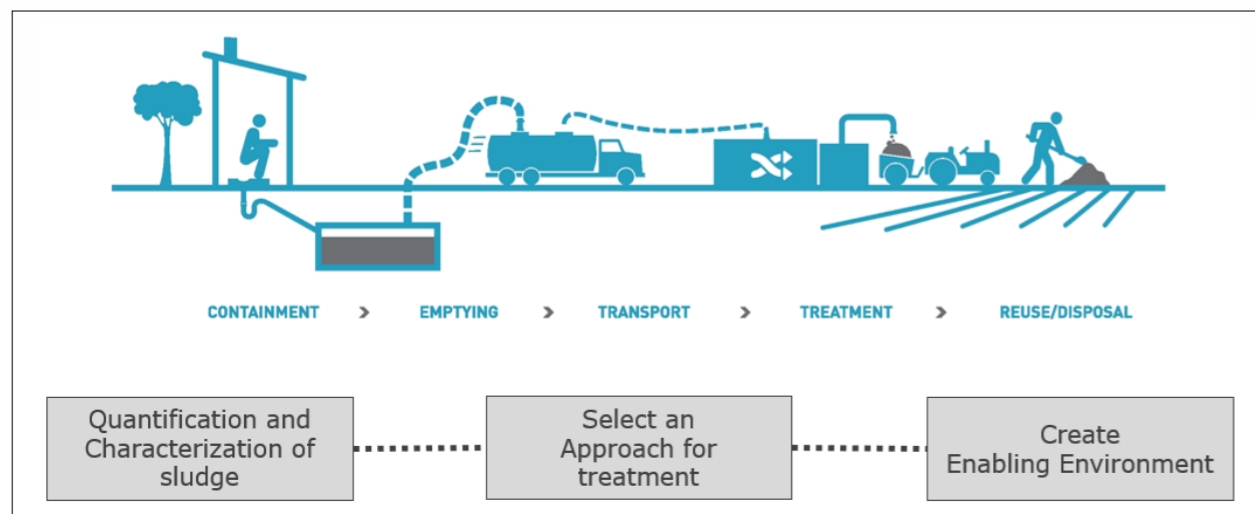

In the first stage, the data collection is carried out mainly across the four steps of service chain—containment, emptying, transport, and reuse/disposal focussing on the quantity, frequency and characteristics of the FSS collected. Additionally, the characterisation of FSS is carried out from various sources such as households, public toilets, community toilets, decentralised wastewater treatment plants etc. Considering the quantity, characteristic of the sludge and the existing infrastructure within the ULB, an approach for treatment has to be defined. Viability checks are performed while defining and selecting the treatment approach. Creating an enabling environment for ensuring sustainability of FSSM is very important. It needs to be noted that success of FSSM not only depends on the technological intervention but also on the non-technical aspects such as stakeholder analysis, stakeholder engagement, etc.

For cities where the extent of sewerage network is very limited and the majority of households rely on on-site sanitation, the ratio of FSS to sewage is likely to be relatively high, and a dedicated FSS treatment facility could prove to be a better option. Effective management of FSS systems entails transactions and interactions among a wide variety of people and organisations representing the public, private and civil society at every step in the service chain, from the household level user, to collection and transport companies, operators of treatment plants, and the final end-user of treated sludge. Sewer systems and FSM can be complementary, and frequently do exist side-by-side in low-income countries.

Cities having a functional STP which is underutilised (both at present and likely in the future), are good candidates for co-treatment options. However, it is important to consider real-time conditions, especially those related to sewage flows and projections as well as sludge flows and projections. The additional sludge volume co-treated should never exceed the spare unutilised capacity of the STP.

Quantification and Characterisation

Quantification and characterisation of the sludge is a very critical step in selecting the approach for FSS treatment. As per the amendments in the ODF++ protocol, the new septic tanks constructed after May 2020 are supposed to conform to the Bureau of Indian Standards (BIS), IS 2470, 1985. These standards provide design criteria for septic tanks as well as ready design and drawing of septic tanks for a population equivalent of 5 to 300 users. The old and new septic tanks should be followed by a soak pit or a dispersion trench. The soak pit/dispersion trench should conform

to BIS, IS 2470 Part II, 1985. These standards provide the design criteria for secondary treatment using anaerobic filters and disposal using soak pits and dispersion trench. It also provides a design criterion with technical drawings for these units.

Quantification is necessary for identifying the equipment required for emptying of septic tanks and subsequent transportation of the sludge to a treatment facility. It is also required to identify the equipment required to co-treat FSS at an STP or to define the capacity of the independent treatment facility. Quantification is of utmost importance when the financial viability of operationalising the FSSM in a town needs to be understood.

To start with quantification of FSS to be managed, the ULB needs to decide the type of desludging to be practiced. There are two types of desludging practices: (1) on-demand desludging and (2) scheduled desludging.

The two methods of sludge quantification are explained below:

A. Sludge production method

Sludge production method is useful in case of scheduled desludging. This method is based on the number of people and the standard sludge production rate. In this method, the FSS quantities are estimated at the household level by determining the excreta production (faeces and urine), the volume of water used for cleansing and flushing, and accumulation rates based on the type of onsite containment technology. According to the IS 2470 Code of practice for Installation of Septic Tanks Part 1 Design criteria and construction) 1985, volume of digested sludge in the septic tank is given as $0.00021 \text{ m}^3/\text{cap}/\text{d}$. The US EPA handbook on Technology Transfer for Septage Treatment and Disposal mentions the average per capita septage generation as $230 \text{ L}/\text{cap}/\text{d}$.

The sludge accumulation rate is highly variable and will change depending on the number of factors discussed in the next session. Due to lack of available information about the onsite sanitation systems, the amount of FSS produced is often assumed based on the following factors:

- A. Number of users;
- B. Location;
- C. Types and number of various onsite systems;
- D. FSS accumulation rates; and
- E. Population of socio-economic levels.

B. Sludge collection method

The sludge collection method needs to be adopted for quantification of FSS in case of demand desludging based on discussions with the FSS collection and transport agencies (both legal and informal). Furthermore, it also uses the existing data of desludging and transportation services to estimate FSS volume. In many Indian cities, the regular and complete collection of waste generated at household level is not practiced. Hence, the sludge collection method is a reliable estimate of quantification of FSS in a city.

The quantity of FSS currently being collected from onsite systems will depend on the FSSM infrastructure, its acceptance and promotion, demand for emptying and collection services, and availability of legal discharge or treatment sites. This method involves structured interviews with key stakeholders such as households, desludging operators, and ULB officials such as sanitary inspectors. Depending upon the responses and statistical analysis of the data collected, inferences are drawn to arrive at the quantity of FSS to be managed in a city.

Figure 7: Factors behind creating an enabling environment

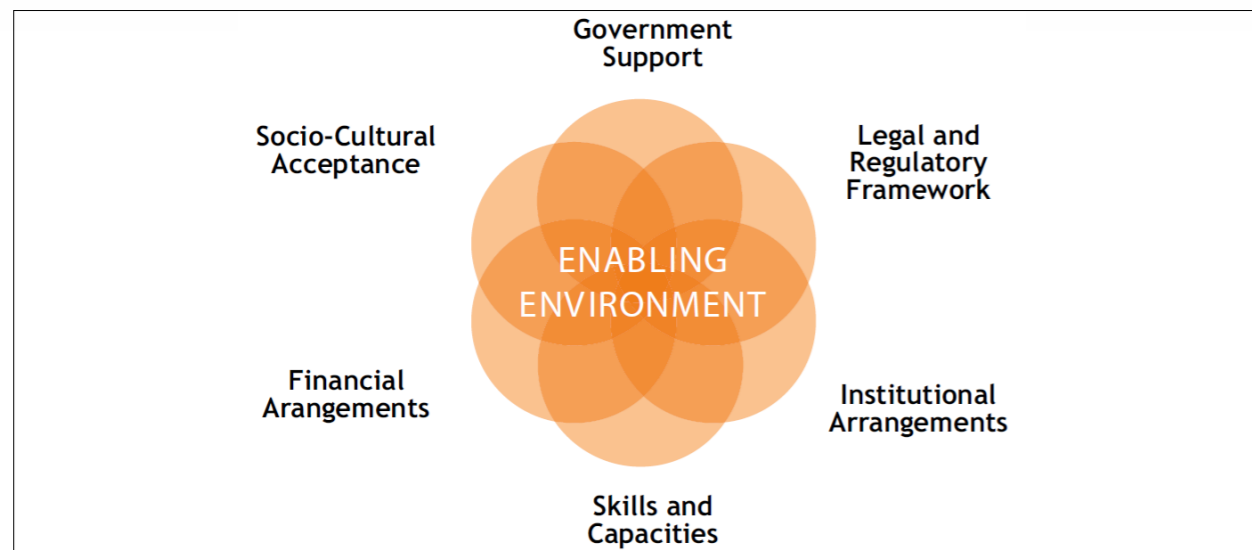

Source: Eawag, Sandec (2008)

An enabling environment is key to any type of intervention, whether it is for the entire FSSM service chain or a particular aspect of a particular aspect of it. Without this, the resources committed for a successful FSSM plan will often be ineffective. For an integrated approach, it is important to understand the conditions in a particular context for the environment to be enabling. The large varieties of potential influences are understood by the six elements as shown in figure 2.

- A. Government support: The absence of political support, often due to conflicting political priorities, is found to be the main reason for the failure of a project. The support from government includes national policy frameworks, sectoral policies, and receptive decision-makers and local authorities.
- B. Legal and regulatory framework: It is important to have clearly defined technical norms and standards to develop a decent and efficient service chain. Major roadblocks in many countries are inconsistent regulations, lack of regulations, poor enforcement of regulations or unrealistic regulations. In order to have an enabling environment via the legal framework, it needs to be transparent, realistic and strictly enforced.
- C. Institutional arrangements: The successful delivery of sanitation services is impossible without a well-defined institutional arrangement. Public institutions and private players play a vital role in enabling the environment as they are interested and also influence the improvement of service provision. Clear understanding of capacities, duties, roles of each stakeholder is necessary to have a strong and efficient institutional setup.
- D. Skills and capacities: Developing the necessary skills and capacities at every level is very important and will often take a long time to develop. It is necessary to identify the capacity gaps and fill these gaps using training workshops, on-the-job courses, etc.
- E. Financial arrangements: The implementation and maintenance of sanitation services requires an enabling financial environment. This is possible from individual users, private organizations, and government agencies.
- F. Socio-cultural acceptance: By matching the proposed sanitation systems to user preferences, it is possible to gain the required socio-cultural acceptance. One of the main reasons behind the failure of sanitation projects is the lack of implemented solutions being socio-culturally embedded in users' daily lives.

These main elements of the enabling environment should be identified during the planning process and their knowledge and understanding should be continuously improved. Without a thorough understanding of the existing environment, problems and bottlenecks will arise during the planning stages. Of course, there never will be 'the perfect enabling environment' – but there are degrees of more or less enabling or disabling factors which can hinder or facilitate progress.

Treatment Approaches

Figure 8: Different treatment approaches in FSSM

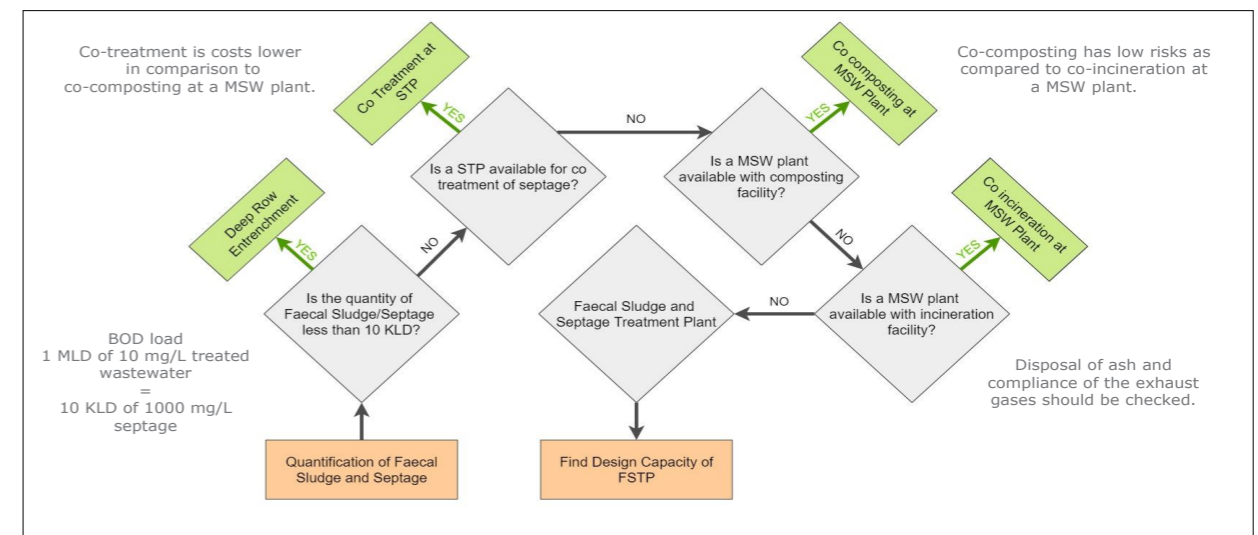

The selection of treatment approach is dependent on certain factors like quantification and characteristics of the FSS, type of sludge, seasonal variations and local conditions. There are different treatment approaches such as: i) Deep row entrenchment; ii) Co-treatment at STP; iii) Co-treatment in MSW management facility; and iv) Faecal Sludge and Septage Treatment Plant (FSSTP).

Deep Row Entrenchment (DRE)

DRE is a process that can act as both a treatment and an end-use option. In this method, deep trenches are dug and subsequently filled with FSS and covered with soil. The surrounding soil acts as a filter causing the solid fraction of the sludge to be arrested while the liquid fraction percolates into the soil. An innovative way to further reap benefits from this method involves planting trees on top. The organic matter and nutrients present in the solid fraction of the FSS are slowly released which are consumed by the trees. DRE is a very simple treatment method and low on operational expenditure as it does not require any infrastructure or mechanical equipment such as pumps that are prone to poor O&M. In addition, growing trees has many benefits such as minimizing odour nuisance, protection against erosion and other potential economic benefits. Moreover, ULBs usually have heavy machinery for earth excavation readily available with them and hence, no specialised equipment is required to adopt this treatment method. However, this method has certain constraints such as availability of sufficient land area with a low groundwater table. Another major constraint is the legal permit to adopt this technology as a treatment method which is absent in many countries.

More details for practicing DRE can be gathered from 'Technical note on shallow and deep trenches for faecal sludge and septage' by the Water, Sanitation and Hygiene Institute (WASHI).

Co-treatment at STP

The role of onsite sanitation technologies is important in the FSSM service chain, as long as the FSS from these systems is safely collected, transported, treated, and then used for resource recovery or safely disposed. Co-treatment of FSS in STP is one of the management approaches. As an STP is not typically designed to handle FSS, one needs to carefully assess the design and treatment capacity of the STP to avoid any process disruptions and failures. Common problems faced during co-treatment of FSS in STP range from deterioration of the treated effluent quality to overloading of tanks. Hence, it is important to study the organic and hydraulic loading at various stages of treatment in the STP. In this approach, FSS can be applied at different stages such as: i) at the manhole chamber before the STP inlet; ii) at the inlet of screens at the STP; and iii) at the sludge handling step of the STP.

Co-treatment at MSW Plant

A MSW plant usually consists of a composting yard for organic solid waste. In some cases, the MSW plant also has an incinerator to process the dry waste into heat which can be reused for various processes within the MSW plant. Co-treatment of FSS can be carried out through these two processes.

Composting: This is a process in which biodegradable waste is decomposed under controlled conditions with the help of microorganisms (bacteria and fungi) under aerobic and thermophilic conditions (60°C). While this process occurs naturally, the role of manual labour involves modulating the microbial load in order to enhance microbiological activity; to restrict undesired environmental and health impacts (smell, rodent control, water and soil pollution) and to achieve the targeted product quality. The end product is a compost that is stable and organic material that can be handled, stored and reused in a safe manner.

The composting of two or more raw materials together such as FSS and solid waste is advantageous because the two materials complement each other. The FSS is found to be relatively high in nitrogen content and water. On the other hand, solid waste is relatively high in organic carbon content and has good bulking quality. Moreover, both these waste products can be safely treated and converted into useful products. The thermophilic conditions attained during composting are highly effective in inactivating pathogens present in FSS and will convert both wastes into a hygienically safe soil conditioner or fertilizer.

Incineration- This is a process where the dry solid waste is incinerated inside a reactor in a controlled manner to extract heat energy. This heat energy is used for various purposes at the plant. For example, heat energy of the flue gas can be used for drying of incoming solid waste thereby reducing the moisture content. The heat energy is also utilised to produce steam which can then be used to generate electricity.

FSS is known to have good calorific value. The calorific value of faecal sludge is approximately 17.3 MJ/kg TSS and that of septage is approximately 12 MJ/kg TSS. Research tells that, addition of FSS also leads to reduction in nitrogen oxides (NOX) and sulphur oxides (SOX) emission from the process.

In conclusion, it is advisable to explore the above options for a safe and efficient management of FSS. But, if it is not possible to co-treat or co-compost FSS, then it is necessary to install a dedicated faecal sludge and septage treatment plant (FSTP). In an FSTP, there are different technologies such as mechanized, non-mechanized or combined systems.

3.4.2 Faecal sludge and septage (FSS) treatment

Treatment objectives

Dewatering or thickening of FSS is an important treatment objective. FSS has a high liquid fraction and reduction of this liquid volume helps in great reduction of transportation and treatment costs. Environmental and public health treatment objectives are achieved through pathogen reduction, stabilisation of organic matter and nutrients, and the safe end-use or disposal of treatment end-products.

Dewatering

One of the very important objectives of FSS treatment is dewatering. Dewatering helps to reduce the volume of sludge to be handled and treated using other treatment mechanisms, hence it reduces the CAPEX significantly. Separating the solid and liquid fraction of FSS helps in optimising the treatment process. For example, in the case of heat drying, dewatering will save a significant amount of energy.

FSS has different dewatering characteristics compared to septage and wastewater sludge, in that it tends to foam upon agitation, and resist settling and dewatering. Duration of onsite storage and sludge age also affects the dewaterability of sludge. Empirical evidence shows that 'fresh' or 'raw' sludge is more difficult to dewater than older, more stabilised sludge. The dewatering, or thickening process can also include addition of dry materials such as sawdust to increase the solids content. This is a common practice in processes such as composting where addition of sawdust also increases the carbon to nitrogen (C:N) ratio. The liquid stream that is produced during dewatering also requires further treatment, as it can have high concentrations of ammonia, salts, and pathogens.

Pathogen removal

The second most important objective is pathogen removal. FSS contains large amounts of microorganisms, mainly originating from the faeces. These microorganisms can be pathogenic, and exposure to untreated FSS constitutes a significant health risk to humans, either through direct contact, or through indirect exposure. Pathogen removal is important to achieve the discharge standards as well as achieve the reuse requirements of treated end products. FSS is known to contain a high number of pathogens and hence indiscriminate disposal of it may result into cross contamination of the water resources. Reduction of pathogens is achieved by various ways such as – starvation, predation, exclusions, desiccation, temperature.

Starvation refers to starving the pathogen to death. Predation refers to introducing or allowing specific types of bacteria to eat (predate) the pathogens. Exclusion refers to physical exclusion of pathogens depending on their size using filters. Desiccation refers to reducing the moisture content to levels where their cell walls ruptures due to dryness.. Pathogens are believed to reduce significantly at temperature above 600° C.

Nutrient recovery

FSS contains significant concentration of nutrients that can be recovered as resources. Otherwise, their direct discharge into the environment can lead to severe contamination. Environmental impacts from nutrients include eutrophication and algal blooms in surface waters and contamination of drinking water (e.g. nitrates leading to methemoglobinemia).

Nutrient recovery is a specific treatment objective which is very important when the end products are intended to be used as soil supplements for improving its characteristics. If managed properly

these nutrients can be used as supplement to synthetic fertilisers in agriculture. However, if not managed properly, it leads to eutrophication of water bodies and it may further lead to contamination of drinking water resources.

Stabilisation

Untreated FSS has high oxygen demand due to presence of readily degradable organic matter which undergoes aerobic respiration. FSS is directly discharged into open environment, it can result in depletion of oxygen in surface waters. The process of stabilisation results in FSS containing organic, carbon-based molecules that are not readily degradable, and which consists of more stable, complex molecules (e.g. cellulose and lignin). Stabilisation is achieved through biodegradation of the more readily degradable molecules, resulting in FSS with a lower oxygen demand. Common indicators of stabilisation include measurement of Volatile Suspended Solids (VSS), BOD, and COD. In addition, stabilisation ensures that organic forms of nutrients present in treated end-products are stable, and can be more predictably and reliably used. Stabilisation also reduces foaming of FSS, resulting in better dewatering.

3.4.3 Treatment mechanism and stages

There are multiple stages of FSS treatment and each stage has a specific treatment objective. The figure below shows treatment mechanisms and examples of treatment units required for specific mechanisms.

Figure 9: Faecal sludge and septage treatment stages and objectives

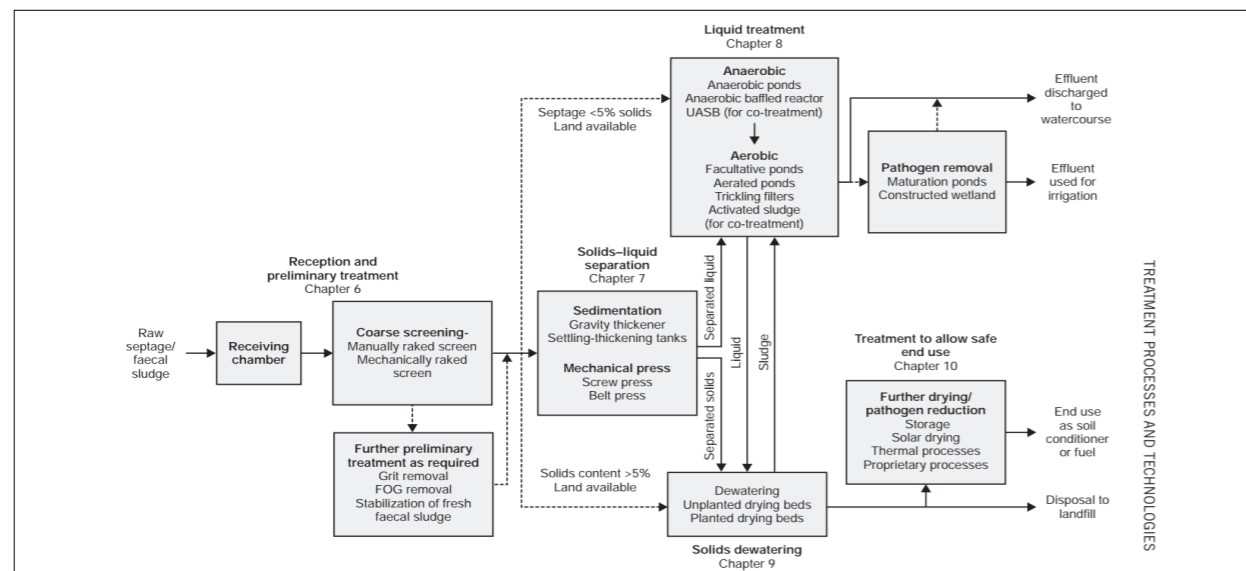

Source: *Faecal Sludge and Septage Treatment* by K. Tayler (2018)

The preliminary treatment of FSS mainly consists of screening. Screening of FSS ensures that solid waste such as plastic bags etc. are not entering into the treatment system. In some cases, the preliminary treatment might also consist of grit removal and fats, oil and grease (FOG) removal. In case of faecal sludge, stabilising the sludge can also be provided at this stage. Stabilising the sludge increases its dewaterability.

The primary stage consists of solid-liquid separation. This stage helps in reducing the liquid fraction of the sludge or increasing the solid content of the sludge. Solid concentration can be increased from 0.5-1% to 10-12% using settling thickening tanks or 20-22% using mechanical press. This stage results into two separate streams of waste – solid (sludge) and liquid.

The liquid treatment is done using wastewater treatment technologies designed to treat high concentration wastewater. The tertiary treatment of disinfection is achieved by using chemical process such as chlorination or photolytic process such as ultra-violet disinfection.

The solid (sludge) stream is further treated by providing dewatering and drying. Drying of sludge also results in disinfection of the biosolids. For pathogen removal, co-composting or thermal treatment of the biosolids is also performed.

Achieving the objectives of co-treatment should entail a proper planning from the beginning on how to ensure complete coverage of both sewerage and non-sewered sanitation systems. The latter mainly deals with waste generated from on-site sanitation systems like septic tanks, pit systems, etc. Waste from these systems are mainly faecal sludge and septage that cannot be left untreated anymore. In order to achieve a complete and safely managed sanitation for any habitation, it is necessary to aim for providing access to safely managed sanitation to everyone. This can be realized through the Citywide Inclusive Sanitation (CWIS) approach in which a wide range of solutions are considered that include both onsite and sewerage, centralised or decentralised, based on the demands of the population and location where the sanitation system is to be implemented.

The CWIS approach aims to shift our mindset regarding sanitation by prioritising service provision and creating an enabling environment, rather than simply building infrastructure. This approach promotes the idea of utilising resources as well as knowledge available to the people whose sanitation needs are to be met with. Hence, the concept of co-treatment targets underutilised sewage treatment systems without focusing on building new infrastructure for managing FSS.

3.4.4 Rationale for co-treatment at STP

There is no scientific definition available that correctly explains the meaning of co-treatment. However, it can be understood as simply a way to co-manage the waste sludge from on-site sanitation systems in networked sewerage systems

When planning for co-treatment, the following information/data should be available for assessment of technical viability. In the absence of reliable data, appropriate conservative figures may be estimated or adopted from literature for planning purposes.

Figure 10: Planning for co-treatment

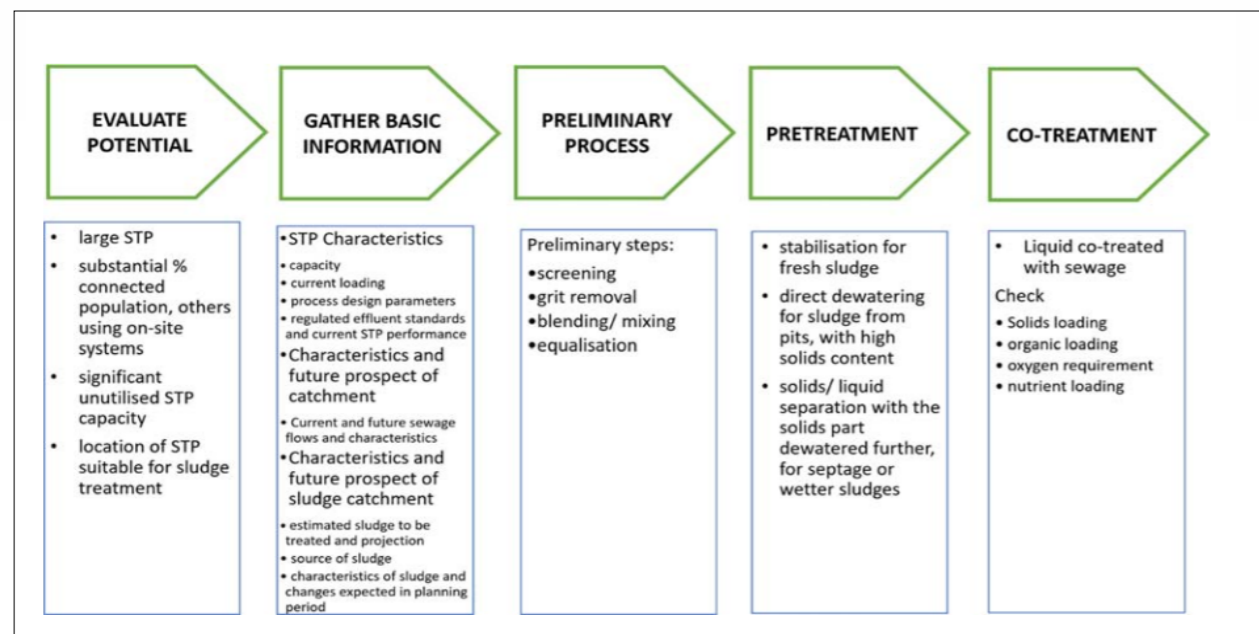

Source: Co-treatment of Septage & faecal sludge in sewage treatment facilities, Dorai Narayana, IWA)

Hydraulic loading

Figure 11: Graph showing the actual sewage flow and the unutilised capacity of a STP including lead times, design capacity and over-built capacity

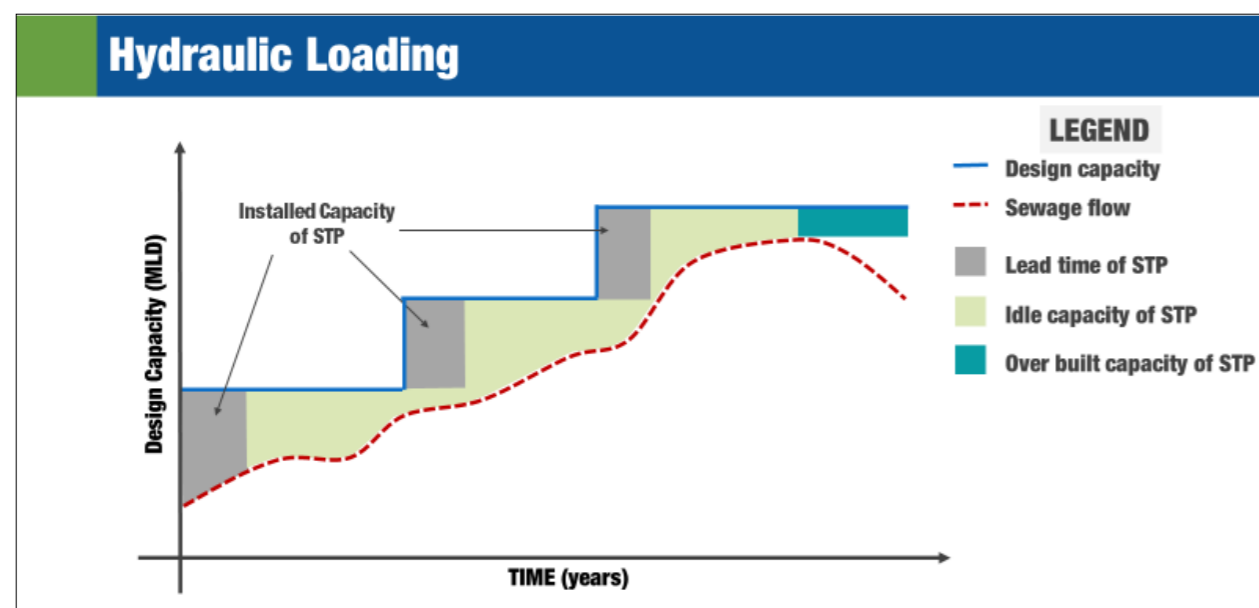

Source: Adopted from CPHEEO Manual, 2013

The graph shows design capacity versus time. The red dotted line represents sewage flow through the sewerage network. STPs are generally designed for a period of 15 years. In the first 5 to 10 years, they are often found to be underutilised. This is represented in the graph by light green colour. The augmentation of design capacity or setting up of another STP happens after 12 to 15 years. Once again, there is significant spare capacity in the initial time period. Thus, unutilized capacity of the designed STP can be utilized for treatment of faecal sludge and septage (FSS).

Organic loading

The STPs are designed based on certain assumptions. As per the CPHEEO Manual on Sewerage and Sewage Treatment (2013), average concentration of wastewater pollutants such as BOD, COD and TSS are taken as 250 mg/L, 425 mg/L and 375 mg/L. The actual concentration of these parameters depends on the water usage, type of waste carried by the sewerage network, design of the sewerage network and its appurtenances, and the periodic operation and maintenance of sewerage network. The average concentration of sewage reaching the STP is observed to be around 60-70% of the designed concentration. Thus, it is observed that the STPs during its lifetime might function at reduced organic loading. Thus, there is a possibility that even at 80-90% hydraulic loading of design capacity, the STP can still receive larger organic load.

These design concentrations are based on the assumptions that the average water consumption by the consumer is 135 LPCD and sewage generated will be 80% of the water consumed. Thus, with change in the water consumption and water usage patterns, the concentration of the parameters also sewage generated will be 80% of the water consumed. changes. The concentration of waste will also change depending on the type of waste. If indiscriminate or illegal discharge of industry effluent is done in the sewerage system, then the concentration will get affected. Design of the sewerage network can also affect the concentrations. If the design / implementation of certain appurtenances of the sewerage network lead to deposition of solids in the network, then this will result in decrease in concentration of the parameters. O&M of the sewerage network helps to maintain the structural integrity and life of the network. If the appurtenances are broken, then infiltration or exfiltration of water can also lead to decrease of increase in the concentration. Such variation is observed during the dry and wet weather flow.

3.5 Notes for trainer

This session acts as a base for understanding the various techniques for faecal sludge & septage management. Thus, it is encouraged to have discussions with the participants regarding their experience in handling such situations & share the learning with the entire group.

3.6 Bibliography

Dorai Narayana (2020), Co-treatment of septage & faecal sludge in sewage treatment facilities, International Water Association (IWA).

United States Environmental Protection Agency (US EPA's), Handbook Septage Treatment & Disposal

Water, Sanitation and Hygiene Institute (2020) Technical Note on Shallow and Deep Trenches for Faecal Sludge / Septage.

Linda Strande, Mariska Ronteltap and Damir Brdjanovic (2014), Faecal Sludge Management-Systems approach for implementation & operation, International Water Association (IWA)

Session

04

Characterisation of liquid waste products: faecal sludge, septage, and sewage

4. Characterisation of liquid waste products: faecal sludge, septage, and sewage

4.1 Session objectives

- A. Understand the difference between faecal sludge, septage, sewage, and sewage sludge.
- B. Learn about characterisation ratios required to select appropriate treatment processes.
- C. Know the operational factors that affect the characteristics of faecal sludge and septage.

4.2 Session plan

Duration- 60 minutes

Topics	Time	Material/Method
Parameters for characterisation	10 min	Powerpoint presentation
Characteristics of sewage	15 min	Powerpoint presentation
Types of sludge & its characteristics	15 min	Powerpoint presentation
Q&A	10 min	Discussion
Part C: Exercise 1- Foundation	10 min	Exercise

4.3 Key facts

- D. Parameters considered for characterisation of FSS are similar to that of wastewater.
- E. FSS, although similar in characteristics, is much stronger than sewage.
- F. Characteristics of FSS change depending upon the source of waste.
- G. Characterisation ratio is considered while choosing the right treatment processes.
- H. Operational factors affect the characteristics of FSS.

4.4 Learning notes

4.4.1 Parameters for characterisation

The parameters used to characterise FSS are same as those used for sewage and are stated below:

- I. Solid concentration (TS, TSS, TVS, VSS)
- J. Chemical oxygen demand(COD)
- K. Biological oxygen demand (BOD⁵)
- L. Nutrients (TKN, NH³-N, Total P)
- M. Pathogens (faecal coliforms, helminth eggs)
- N. Metals

The slowly biodegradable COD content of faecal sludge is much higher than septage. Hence, in order to stabilise the faecal sludge, anaerobic digestion with higher retention time is required. Septage has a significantly higher amount of particulate non-biodegradable COD. This means septage does not need much stabilisation and COD reduction in septage can be achieved by simply separating the solid and liquid fractions.

4.4.2 Characteristics of sewage

The main physical, chemical and biological characteristics of domestic sewage (Source: Wastewater Characteristics, Treatment and Disposal by Marcos von Sperling, IWA, 2007) are given in following tables:

Table 3: Physical characteristics of domestic sewage

Parameters	Description
Temperature	<ul style="list-style-type: none"> Slightly higher than in drinking water Variations according to the seasons of the year Influences microbial activity, solubility of the gases, viscosity of the liquid
Odour	<ul style="list-style-type: none"> Fresh domestic sewage: oily odour, relatively unpleasant Septic tank sewage: foul odour (unpleasant), due to hydrogen sulphide gas & other decomposition by-products Industrial wastewater: characteristic odours
Colour	<ul style="list-style-type: none"> Fresh sewage: slight grey
Turbidity	<ul style="list-style-type: none"> Caused by a great variety of suspended solids Fresher or more concentrated sewage- generally greater turbidity

Table 4: Chemical characteristics of domestic sewage

Parameters	Description
Total Solids	Organic and inorganic; suspended and dissolved; settleable
Suspended	<ul style="list-style-type: none"> Part of organic & inorganic solids that are non-filterable
i. Fixed	i. Mineral compounds, not oxidizable by heat, which are part of suspended solids
ii. Volatile	ii. Organic compounds, oxidizable by heat, which are part of suspended solids
Dissolved	<ul style="list-style-type: none"> Part of organic & inorganic solids that are filterable.
i. Fixed	i. Mineral compounds of dissolved solids
ii. Volatile	ii. Organic compounds of dissolved solids
Settleable	<ul style="list-style-type: none"> Part of organic & inorganic solids that settle in 1 hour in an Imhoff cone. Approx. indication of settling in a sedimentation tank.
Organic Matter	Heterogeneous mixture of various organic compounds. Main components- proteins, carbohydrates & lipids.
BOD ⁵	<ul style="list-style-type: none"> Biological oxygen demand. Measured at 5 days & 20°C. Associated with the biodegradable fraction of carbonaceous organic compounds. Measure of the oxygen consumed after 5 days by the microorganisms in the biochemical stabilization of the organic matter.
COD	<ul style="list-style-type: none"> Chemical oxygen demand. Represents the quantity of oxygen required to chemically stabilize the carbonaceous organic matter. Uses strong oxidizing agents under acidic conditions.
Ultimate BOD	<ul style="list-style-type: none"> Ultimate biological oxygen demand. Represents the total oxygen consumed at the end of several days, by the microorganisms in the biochemical stabilization of the organic matter.
TOC	<ul style="list-style-type: none"> Total organic carbon. Direct measure of the carbonaceous organic matter. Determined through the conversion of organic carbon into carbon dioxide.
Total Nitrogen	<ul style="list-style-type: none"> Total nitrogen includes organic nitrogen, ammonia, nitrite & nitrate. It's an essential nutrient for microorganisms' growth in biological wastewater treatment. Organic nitrogen & ammonia together are called Total Kjeldahl Nitrogen (TKN).
Organic nitrogen	<ul style="list-style-type: none"> Nitrogen in the form of proteins, amino acids & urea.
Ammonia	<ul style="list-style-type: none"> Produced in the 1st stage of the decomposition of organic nitrogen.
Nitrite	<ul style="list-style-type: none"> Intermediate stage in the oxidation of ammonia. Practically absent in raw sewage.
Nitrate	<ul style="list-style-type: none"> Final product in oxidation of ammonia. Practically absent in raw sewage.
Total Phosphorus	<ul style="list-style-type: none"> Total phosphorus exists in organic & inorganic forms. It is an essential nutrient in biological wastewater treatment.
Organic phosphorus	<ul style="list-style-type: none"> Combined with organic matter.
Inorganic phosphorus	<ul style="list-style-type: none"> Orthophosphates & Polyphosphates.
pH	<ul style="list-style-type: none"> Indicator of the acidic or alkaline conditions of the wastewater. A solution is neutral at pH 7. Biological oxidation processes normally tend to reduce the pH.

Parameters	Description
Alkalinity	<ul style="list-style-type: none"> Indicator of the buffer capacity of the medium. Caused by the presence of bicarbonate, carbonate & hydroxyl ions.
Chlorides	<ul style="list-style-type: none"> Originating from drinking water & human and industrial wastes.
Oils & grease	<ul style="list-style-type: none"> Fraction of organic matter which is soluble in hexane. In domestic sewage, the sources are oils & fats used in food.

Table 5: Biological characteristics of domestic sewage

Organism	Description
Bacteria	<ul style="list-style-type: none"> Unicellular organisms Present in various forms & sizes Main organisms responsible for stabilization of organic matter Some bacteria are pathogenic, causing mainly intestinal diseases
Algae	<ul style="list-style-type: none"> Autotrophic photosynthetic organisms, containing chlorophyll Important in the production of oxygen in water bodies & in some sewage treatment processes In lakes & reservoirs they can proliferate in excess, deteriorating the water quality
Fungi	<ul style="list-style-type: none"> Predominantly aerobic, multicellular, non-photosynthetic, heterotrophic organisms Also, of importance in the decomposition of organic matter Can grow under low pH conditions
Protozoa	<ul style="list-style-type: none"> Usually unicellular organisms without cell wall Majority is aerobic or facultative Feed themselves on bacteria, algae & other microorganisms Essential in biological treatment to maintain an equilibrium between various groups Some are pathogenic
Viruses	<ul style="list-style-type: none"> Parasite organisms, formed by association of genetic material (DNA or RNA) & a protein in structure Pathogenic & frequently difficult to remove in water or wastewater treatment

4.4.3 Types of sludge & its characteristics

Assessment of faecal sludge and septage treatment requirements must start from an understanding of the main sanitation options and ways in which they influence subsequent links in the sanitation chain. Compared to the sludge from wastewater treatment plants or to municipal wastewater, FSS characteristics differ widely according to location (from household to household, from city district to city district, from city to city). A basic distinction can usually be made between different types of sludge based on collection are either relatively fresh or contain a fair amount of recently deposited excreta (e. g. sludge from frequently emptied, unsewered public toilets) and the sludge which have been retained in on-plot pits or vaults for months or years and which have undergone biochemical degradation to a variable degree (e.g. sludge from septic tanks – septage). Moreover, varying amounts of water or wastewater, which have accumulated in vaults or pits, are collected alongside with the solids.

Faecal sludge is referred to the sludge obtained from the containment unit such as a line pit (pit latrine). It is generally fresh and yellowish in colour. This is due to the fact that the content of the pits do not undergo digestion and the pits need to be frequently emptied. The water content of faecal sludge is relatively low as compared to other forms of sludge. As a result, it has higher solid content and corresponding BOD concentration. It requires a higher degree of treatment.

Septage is referred to the sludge obtained from the on-site containment units such as septic tanks or holding tanks. It is well digested and blackish in colour as it has undergone digestion over a period of time before being emptied. The water content of septage is higher than that of faecal sludge (sometimes as high as above 95%). As a result of this, it has lower solid content and corresponding BOD concentration. It requires a lower degree of treatment.

Figure 12: Faecal sludge being emptied at a FSTP



Figure 13: Septage being emptied at a FSTP



Characteristics of sludge

The characteristics of sludge are influenced by many factors. However, it primarily depends on the origin of sludge, type of containment unit and the duration for which it was stored in the containment unit. Sewage, which is usually collected and conveyed using a sewerage network, reaches the treatment facility in a few hours from the point of generation. The quantum of water used for flushing the waste and the turbulent flow in pipes and pumping stations, make sewage a homogenous mixture by the time it reaches the treatment facility. Hence, the characteristics of faecal sludge and septage varies significantly from sewage and require a higher degree of treatment. Table 4 gives an overview of the characteristics of faecal sludge, septage and sewage.

FSS is highly concentrated in all parameters when compared to sewage. Evidence suggests that in some cases, it is up to 68 times more concentrated as compared to sewage.

FSS is stronger than the sewage sludge formed at STP and its characteristics are still different. However, the treatment mechanisms used for the management of sewage sludge can be tweaked and used for management of FSS.

The characterisation parameters are important and convey a lot about the constituents of liquid waste and their interdependence. The following table represents characteristics of sludge obtained from containment units linked to public toilets, septic tanks of household and medium strength wastewater.

Table 6: Characteristics of faecal sludge, septage and sewage

Parameters	Faecal Sludge	Septage	Sewage
Characteristic	Highly concentrated, fresh excreta, stored for weeks or months	Low concentration, more stabilized, stored for several years	Tropical sewage
COD [mg/L]	20 - 50,000	< 10,000	500 - 2,500
COD : BOD Ratio	2 - 5	5 - 10	2
NH ⁴ - N [mg/L]	2 - 5,000	< 1,000	30 - 70
Total Solids [%]	≥ 3.5%	< 3.0%	< 1.0%
Suspended Solids [mg/L]	≥ 30,000	≈ 7,000	200 - 700
Helminth Eggs (no./L)	20 - 60,000	≈ 4,000	300 - 2,000

Source: USEPA Handbook on Septage Treatment and Disposal

The COD:BOD ratios tell us the fraction of organic solids that are easily degradable. A higher ratio indicates the higher quantity of solids that are difficult to digest. The organic content to nitrogen ratio also indicates that the organic concentrations are not sufficient for nitrogen removal by denitrification.

4.4.4 Operational factors affecting the sludge characteristics

Local conditions and operational factors which are heavily influenced by habits and behaviour of people impact the FSS characteristics. Following are some of the key operational factors which have an impact on the sludge characteristics:

- A. Toilet usage: The household habits have a major impact on the variability of FSS characteristics in the onsite sanitation system. The number of people using the toilet, waste streams such as greywater, kitchen waste, etc. affect the rate at which an onsite containment system is filled. If kitchen waste is included without any oil and grease trap, then fat, oil and grease (FOG) concentration of the waste will be high. Based on toilet usage (dry v/s wet), the volume of flush water used, anal cleansing method, the solid concentration varies significantly.
- B. Storage duration: The duration for which FSS is stored in an onsite containment system before being collected and transported to a treatment location greatly affects the characteristics. This is because a longer storage duration causes digestion of the organic matter. Furthermore, the frequency of emptying an onsite sanitation system varies greatly based on the volume and number of users. FSS stored in a household septic tank for a period of years will undergo more stabilization than FSS from public toilets. Also, a longer storage period results in a dense FSS collected at the bottom of a containment unit due to compaction. Often, this dense part of FSS is not collected as it becomes difficult to pump it out during the emptying process.
- C. Inflow and infiltration: Inflow and infiltration of leachate into the environment from a containment system and/or groundwater into a containment system affects the concentration and volume of FSS. If the liquid component of FSS leaches out of a containment unit, then the filling rate is slower and accumulated sludge is thicker. The variability in FSS characteristics due to this factor can be determined by understanding whether the onsite containment unit is completely lined, partially lined, unlined, connected to soak pits, and the quality of construction.

D. Collection method: The emptying method has a great influence on the FSS characteristics. FSS present at the bottom of a containment system is often thick and cannot be pumped out easily. Hence, mechanical emptiers often dilute this thick FSS with water and ease the pumping process. Also, if lower capacity pumps are used in the emptying of FSS it will lead to only the liquid component to be collected easily leaving the thick, solid component in the containment unit.

4.5 Notes for trainer

There are different parameters that define the characterisation of various sludge types. An insight into these parameters will help the participants to understand the intricacies while designing and planning any treatment options. The trainers can give a better perspective in making them understand about the importance of knowing such details.

This session contains an exercise which has been explained in Part C of this module. It is advised to solve this specific exercise before training in order to understand the basic design parameters of wastewater such as concentration, septage load, peak flow rate, and loading rate.

4.6 Bibliography

Dorai Narayana (2020), Co-treatment of septage & faecal sludge in sewage treatment facilities, International Water Association (IWA).

United States Environmental Protection Agency (US EPA's), Handbook Septage Treatment & Disposal

Linda Strande, Mariska Ronteltap and Damir Brdjanovic (2014), Faecal Sludge Management-Systems approach for implementation & operation, International Water Association (IWA)

Marcus Von Sperling (2007), Wastewater characteristics- treatment & disposal, International Water Association (IWA).

Session

05

Sewage treatment plant and co-treatment

5. Sewage treatment plant and co-treatment

5.1 Session objectives

- A. Understand the objectives, processes and different stages of sewage treatment.
- B. Learn the approach for co-treatment of faecal sludge and septage (FSS) with sewage in sewage treatment plant and know about the impacts of unscientific addition of FSS on sewage treatment processes.

5.2 Session plan

Duration- 75 minutes

Activity	Time	Material/Method
Forming treatment chain at sewage treatment plant	15 min	Group Activity
Objectives of sewage treatment	10 min	Powerpoint presentation
Treatment mechanisms & stages	15 min	Powerpoint presentation
Co-treatment of sludge	15 min	Powerpoint presentation
Q & A	10 min	Discussions
Part C: Exercise 2 – Sewage Treatment Plant	10 min	Discussions

5.3 Key facts

- C. The purpose and goal of treatment of sewage should be clear before considering different options for treatment.
- D. Sewage treatment technologies consist of different stages or components whose design needs to be understood while designing the system.
- E. Nitrification, denitrification and aerobic treatment is needed in order to achieve standards of treatment.
- F. Sewage treatment system design needs to be studied before deciding points of addition of sludge while adopting the co-treatment approach.

5.4 Learning notes

5.4.1 Group activity - forming treatment chain of sewage treatment plant

The following activity is to be done in groups. Each group is provided with colour cards or cut-outs of the treatment units which are employed in a sewage treatment plant. The task is to arrange the treatment units and link them together in order to complete the treatment process. After placing the cards, the group also has to draw arrows linking the units together and show the flow of different products from one unit to another. Each group will work on two treatment plants.

Components

Treatment Plant I		Treatment Plant II	
Mechanized screens	Digester	Anaerobic settler	Polishing Pond
Pond clarifier	Secondary clarifier	Planted gravel filter	Anaerobic filter
Polymer dosing	Aeration reactor	Anaerobic baffled reactor	Bar screen
Chlorination	Screw press		

Sludge thickener	Grease & grit removal		
Sand and charcoal filter	Inlet sump		
Discharge Outlet	Dewatered Sludge		
Blowers	Sludge pumps		

Treatment plant 1: Centralised STP

The first treatment plant is a centralised STP based on an activated sludge process. The STP consists of following stages of treatment: preliminary treatment (also known as headworks), primary treatment, secondary treatment, and tertiary treatment (consisting of disinfection of the secondary treated water). Different types of sludge are produced at different stages of the sewage treatment and need to be handled with an appropriate sludge handling facility. The sludge treatment facility consists of a gravity thickener, a digester and a dewatering stage. The diagram below explains the placement of each treatment unit in a centralised sewage treatment plant and the links between them.

Figure 14: Flow diagram for a centralised sewage treatment plant

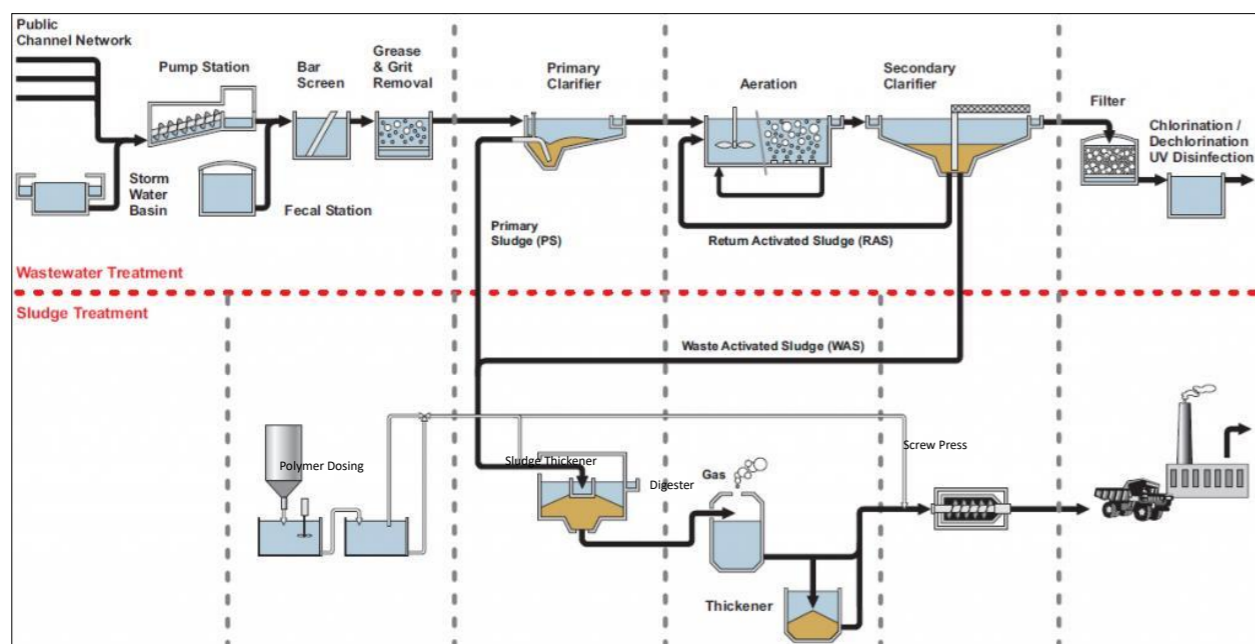

Source: www.sswm.info

Treatment plant 2: Decentralised STP

The second treatment plant is a decentralised STP based on low operation and maintenance treatment units. It also consists of three stages of treatment: preliminary treatment (usually consisting of manually raked bar screens), primary treatment, secondary treatment (anaerobic as well as aerobic treatment units) and tertiary treatment which consists of disinfection stage.

Sludge produced in the plant is stored in treatment units as it assists in improving the treatment efficiency of units. The anaerobic treatment units need to be desludged depending on the frequency it is designed for. The diagram below indicates various stages of this treatment system.

Figure 15: Flow diagram of decentralised sewage treatment plant

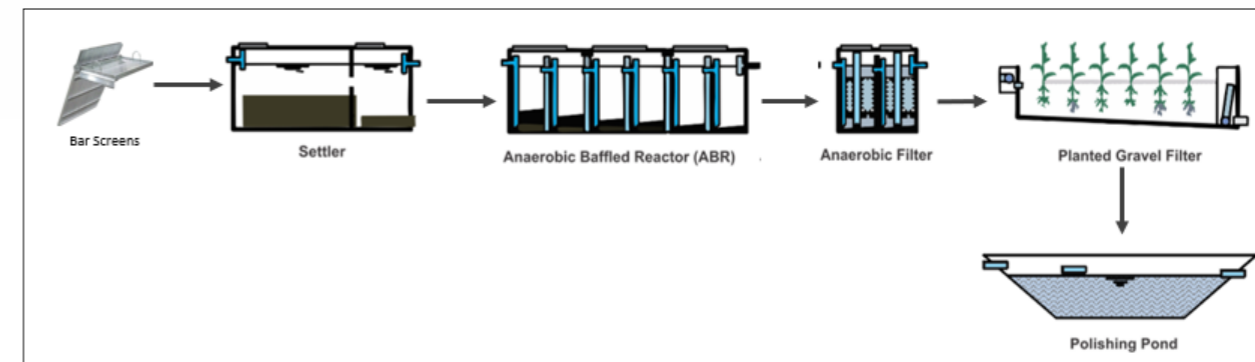

Source: www.borda.org

5.4.2 Objectives of sewage treatment

The ultimate aim of sewage or wastewater treatment is to reduce the quantity of pollutants entering the natural environment. In some cases, the specific goals can change and require specific treatment methods to be applied. Specific goals of sewage treatment can be as follows:

- G. To supply water to the industry such as cement, pipe manufacturing, stone cutting or thermal power plant as process water.
- H. To reduce eutrophication of the surface water bodies such as lakes.
- I. To reduce the dependency on rain and irrigation canal water by reuse in agriculture in drought prone areas.
- J. To improve the groundwater levels through indirect aquifer recharge techniques.

Wastewater treatment processes are of different types: physical, biological, chemical, and photolytic.

K. Physical processes are based on physical characteristics of the wastewater constituents. It mainly targets specific gravity or size of particles which aids solid-liquid separation. Most of these methods are based on physical forces, e.g. screening, mixing, flocculation, sedimentation, flotation, and filtration.

L. Biological processes rely on the microorganisms to carry out digestion of organic matter under anaerobic or aerobic conditions. In any treatment process, biological processes are considered as the most important treatment component as they have the highest treatment efficiency.

M. Chemical processes rely on the use of chemicals either to treat the water (e.g. Ozonation- to kill pathogens) or to assist the physical or biological processes (e.g. Alum or ferric chloride to coagulate the sludge).

N. Photolytic processes rely on photons falling in specific spectrum of light to treat the wastewater directly (e.g. UV to kill pathogens) or indirectly (e.g. Photosynthesis helps to uptake the nutrients from the wastewater in case of constructed wetlands).

Design parameters

Design of a wastewater treatment plant depends on several parameters. The importance of these design parameters varies on a case-to-case basis. The important design parameters are listed below:

- O. Organic loading (kgBOD/d, kgCOD/d),
- P. Volumetric loading rate (m³/d)
- Q. Temperature (°C)
- R. Hydraulic retention time (HRT) (hours or days)
- S. Sludge age (d)
- T. Biomass yield (kgVSS/kgCOD)
- U. Up flow velocity (m/s)
- V. Specific surface area (m²/m³)

5.4.3 Treatment mechanisms and stages

The treatment methods are composed of unit operations and processes, and their integration as per desired treatment standards makes up a treatment system. The concept of unit operations and unit processes are frequently used interchangeably, because they can occur simultaneously in the same treatment unit.

A wastewater treatment facility consists of several treatment stages combining different treatment processes. In case of a wastewater treatment plant, the wastewater is firstly subjected to preliminary treatment (screening, FOG removal) and then a primary treatment. In this stage, the physical treatment processes are used to remove the easily settleable solids usually known as grit. In the secondary stage, biological treatment processes remove the organic pollutants represented by BOD and COD. The digestion of organic pollutants is carried out by anaerobic and aerobic microorganisms. In the tertiary stage, chemical or photolytic treatment process is used to disinfect the wastewater.

Figure 16: Different wastewater treatment processes

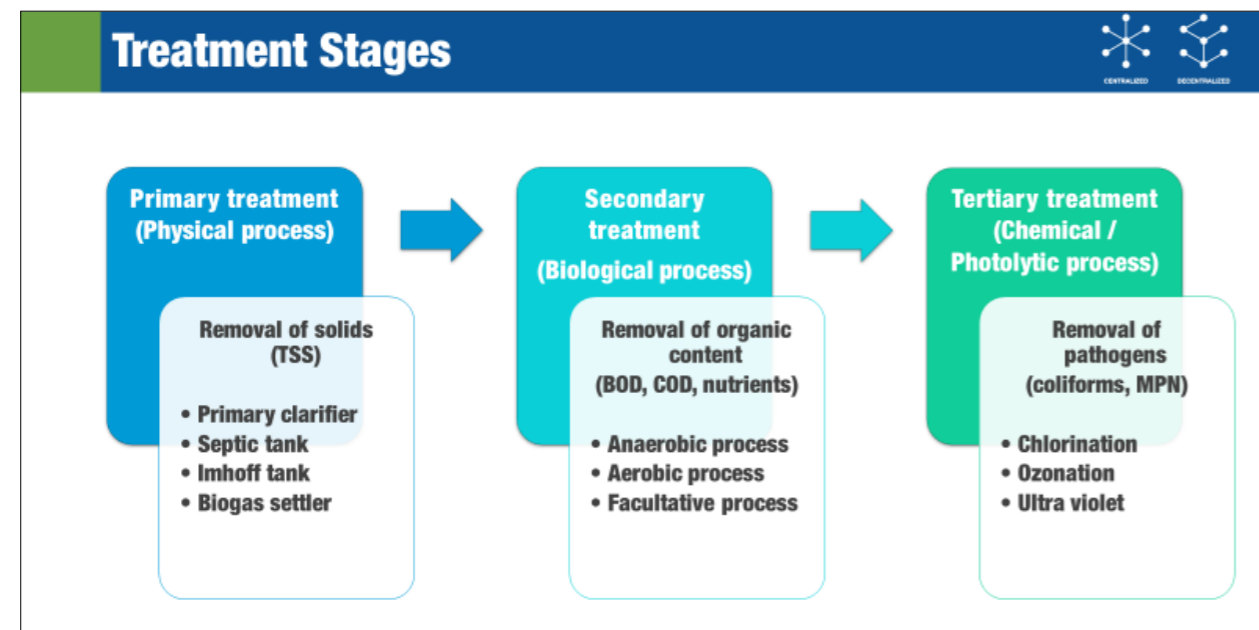

Source: Adopted from Metcalf & Eddy, 2013

A. Preliminary treatment

Preliminary treatment is mainly intended for the removal of coarse solids & grit. The removal mechanisms are based on the physical forces such as gravity. Besides solids and grit removal units, some wastewater treatment consists of a flow measurement unit. The flow measurement is generally carried out using a standardised flume (e.g. Parshall flume), where the measured liquid level can be correlated with the flow. Weirs (rectangular or triangular) and closed-pipe measurement mechanisms can also be adopted.

Screens

Screening is essential for the removal of floating materials which are mainly sachets, plastic sheet bits, leaves, fibres, rags, etc. If these are not removed, they clog the pumps and entangle in the impellers leading to mechanical failures. Hence, the screens are used in the initial stage of a wastewater treatment plant. A screen is a device with openings/slits, generally of uniform size. The screening element may consist of parallel bars, rods, gratings or wire mesh or perforated plates and the openings may be of any shape, although generally they are contrived from circular or rectangular bars.

Figure 17: Schematic diagram of a mechanised bar screen

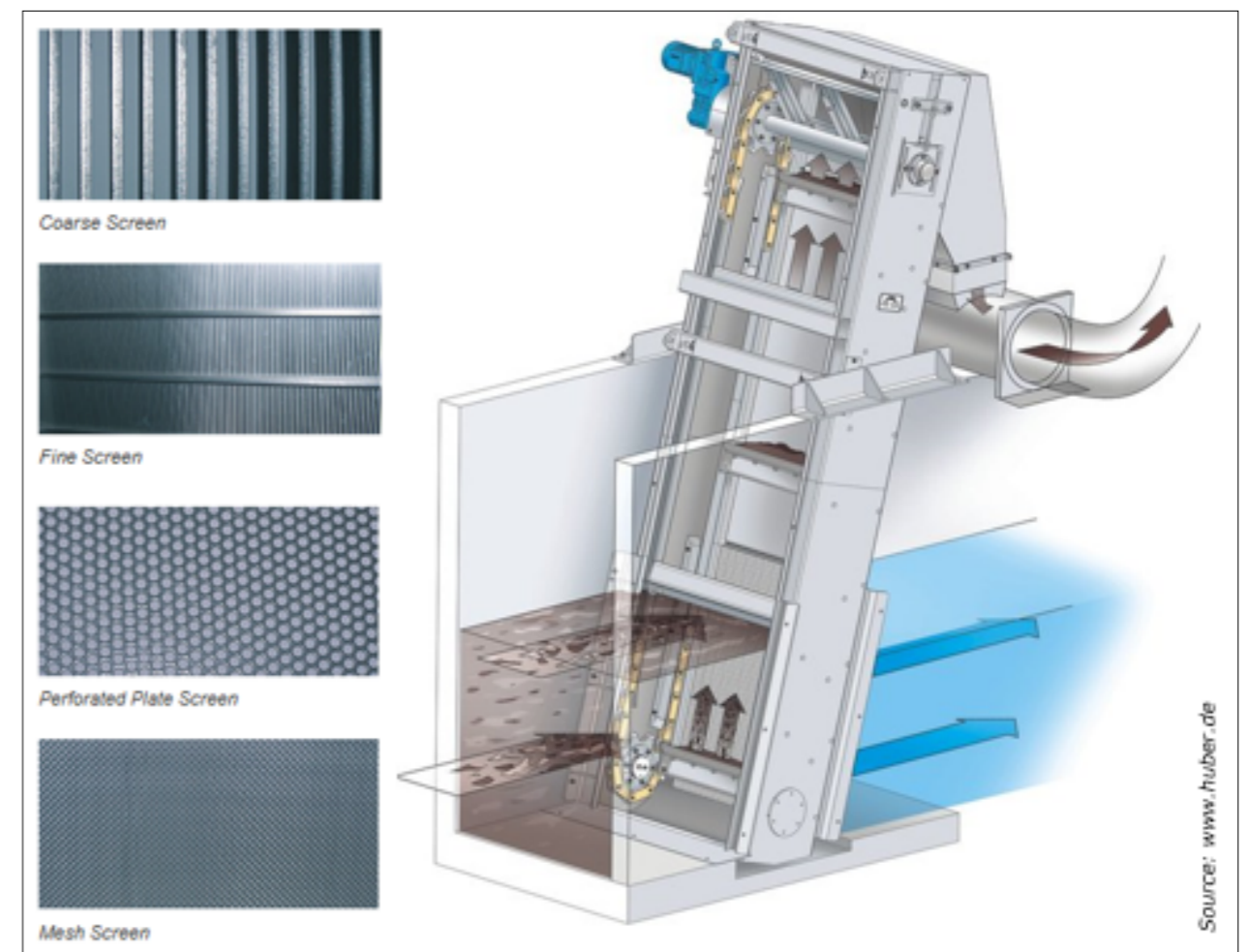

Source: www.huber.de

Table 7: Design criteria for screens

Operation	Size of opening (mm)	Moisture content (%)	Specific weight (kg/m ³)	Volume of screening (L/1000 m ³)	
				Range	Typical
Coarse screen	12.5	60-90	700-1100	37-74	50
	25	50-80	600-1000	15-37	22
	37.5	50-80	600-1000	7-15	11
	50	50-80	600-1000	4-11	6
Fine screen	12.5	80-90	900-1100	44-110	75
Rotary drum screen	6.25	80-90	900-1100	30-60	45

Source: Metcalf and Eddy (2003), Wastewater engineering

Grit removal

Grit removal is the second unit necessary to protect the moving parts of mechanical equipment, pump elements from abrasion and accompanying abnormal wear and tear. Additionally, the removal of grit also reduces the frequency of cleaning of digesters and settling tanks. It is desirable to provide screens or comminuting devices ahead of grit chambers to reduce the effect of rags and other large floating materials on the mechanical equipment, in case of mechanized grit chambers. Two commonly used types of grit chambers are briefly discussed below.

Horizontal flow - Circular grit chamber

In the horizontal flow circular type grit chamber, wastewater passes through the chamber in a horizontal direction and the straight-line velocity of flow is controlled by the dimensions of the unit, an influent distribution gate and a weir at the effluent end. The units are designed to maintain the horizontal velocity in between 0.25 – 0.4 m/s. These are normally designed to remove 95% of solid particles (usually of diameter 0.15 mm) at peak flow.

Figure 18: Schematic diagram of circular grit chamber

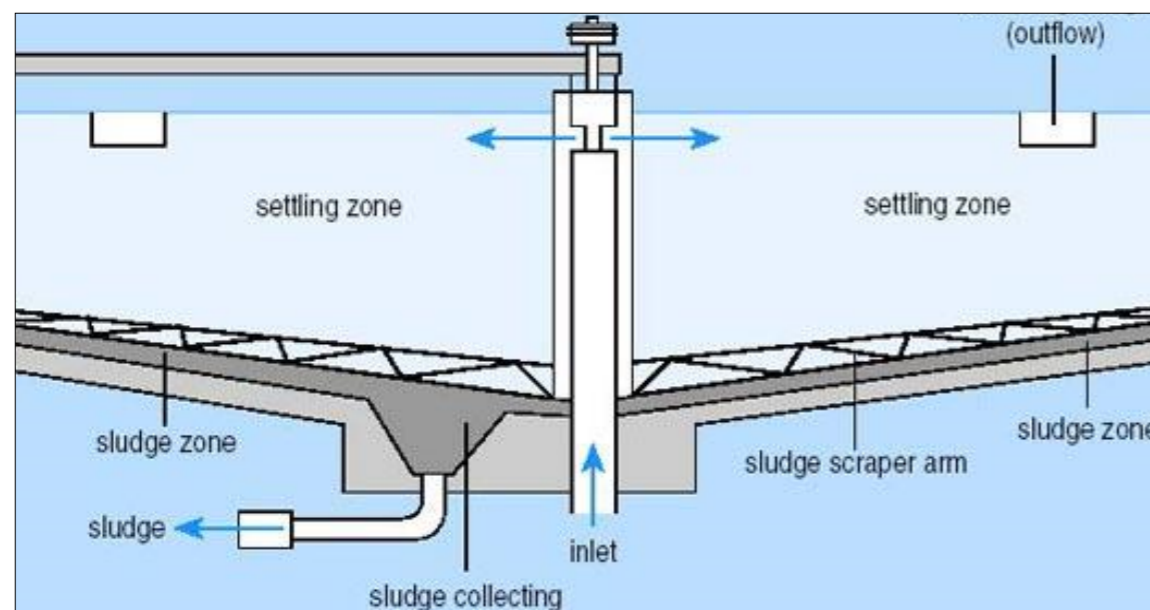

Source: <http://sewagetreatment.us>

Aerated grit chamber

An aerated grit chamber is a special form of grit chamber consisting of a standard spiral-flow aeration tank provided with air-diffusion tubes placed on one side of the tank, 0.6 to 1 m from the bottom. The grit particles tend to settle down at the bottom of the tank at rates depending on the particle size and bottom flow velocity of roll of the spiral flow. This is in turn controlled by the rate of air diffusion through air diffusers and shape of the tank. The heavier grit particles with their higher settling velocities drop down to the floor whereas the lighter organic particles are carried with roll of the spiral motion and eventually out of the tank.

Figure 19: Schematic diagram of aerated grit chamber

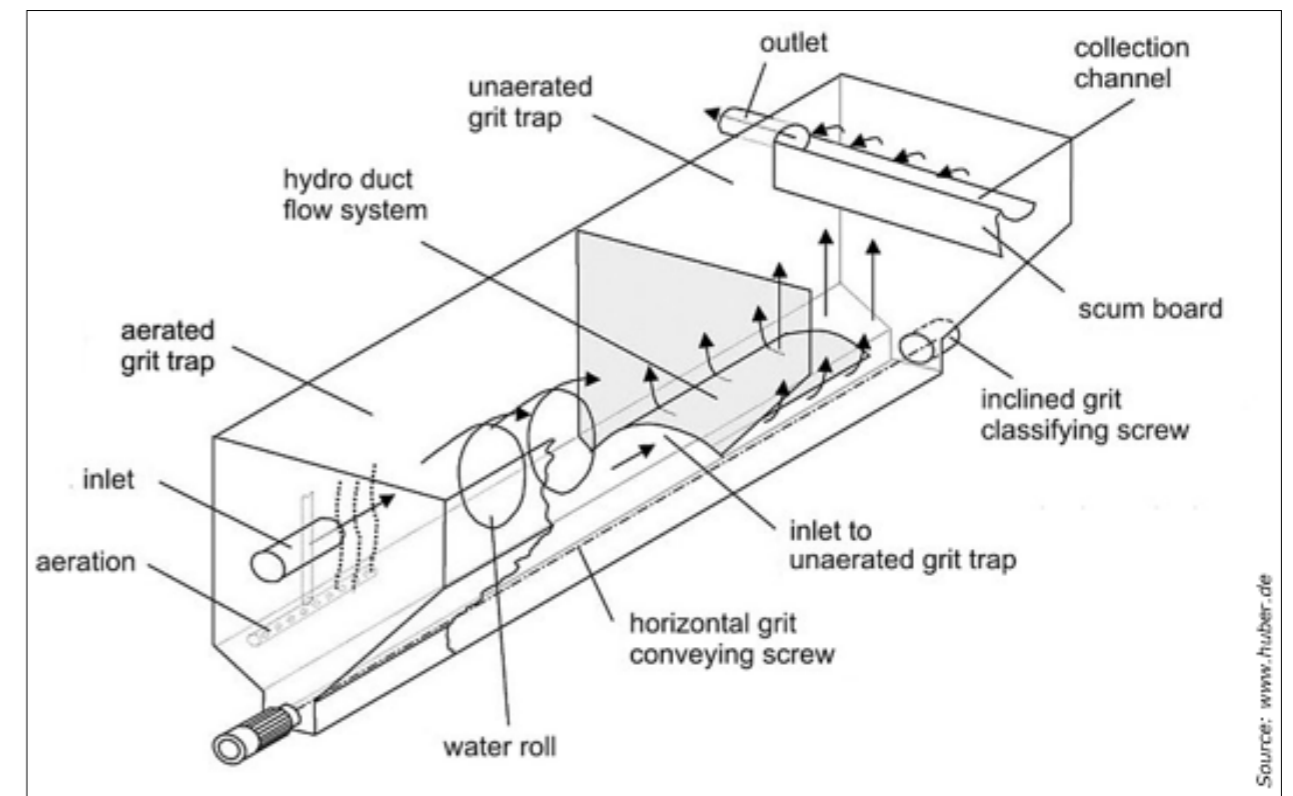

Source: Metcalf & Eddy (2003)

B. Primary treatment

Primary treatment aims at the removal of settleable suspended solids & floating solids. After passing through the preliminary treatment units, wastewater often contains non-coarse suspended solids. The partial removal of these solids can be achieved in sedimentation units. A significant part of these suspended solids comprises of organic matter. In this way, its removal by simple processes such as sedimentation implies a reduction in the BOD load directed to the secondary treatment, where its removal is more expensive. However, it is important to note that the settled solids from primary treatment are to be treated for the removal of organic pollutants before the desired end use.

Primary clarifier

The primary clarifier generally removes 30 to 40% of the total BOD and 50 to 70% of suspended solids from the raw wastewater. The flow through velocity of 1 cm/sec at average flow is used for design with a detention period in the range of 90 to 150 minutes. This horizontal velocity will be generally effective for removal of organic suspended solids of size above 0.1 mm. Primary sedimentation tanks can be designed as a circular or rectangular tank using average dry weather

flow and checked for peak flow condition. The numbers of tanks are determined by limitation of tank size. The diameter of a circular tank may range from 3 to 60 m (up to 45 m typical) and it is governed by structural requirements of the trusses which supports scrapper in case of mechanically cleaned tanks. Rectangular tank with length 90 m is in use, but usually a length of tank higher than 40 m is not preferred. The depth of the mechanically cleaned tank should be as shallow as possible, with minimum 2.15 m. The average depth of the tank used in practice is about 3.5 m. The floor of the tank is provided with a slope of 6 to 16 % (8 to 12 % typical) for circular tanks and 2 to 8% for rectangular tanks.

Figure 20: Schematic diagram of primary clarifier

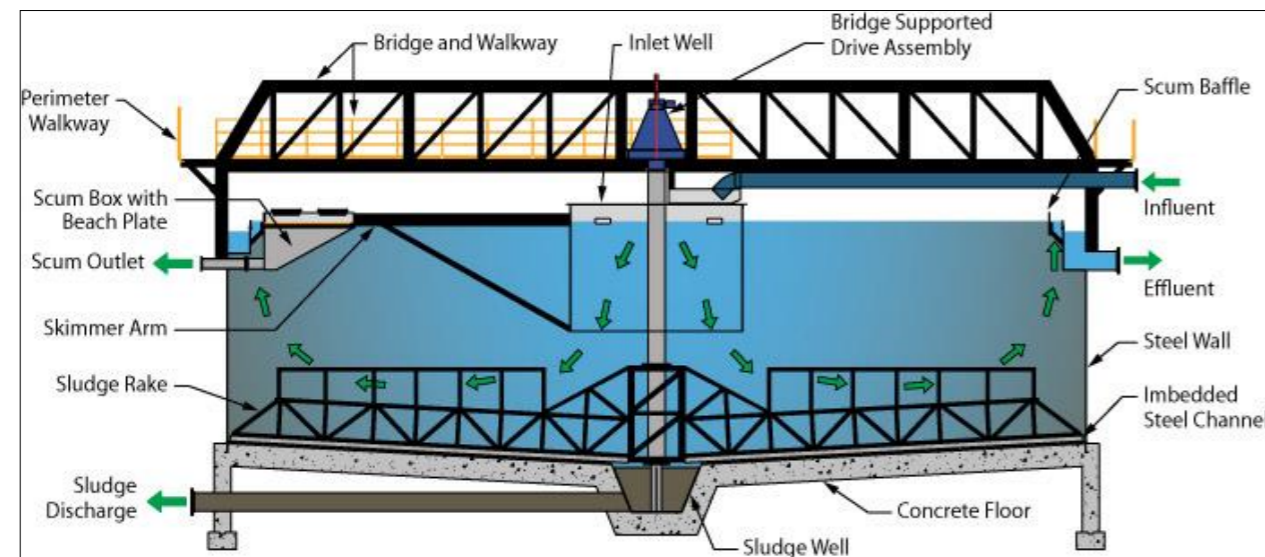

Source: www.sswm.info

C. Secondary treatment

The main objective of secondary treatment is the removal of organic matter. Organic matter is present in the following forms:

- Dissolved organic matter (soluble or filtered BOD) that cannot be removed by mere physical operations, such as sedimentation in primary stage.
- Organic matter in suspension (suspended or particulate BOD), which is largely removed during primary treatment - sedimentation; but, some part of solids with lower settleability (finer solids) that remains in the liquid fraction.

The secondary treatment processes are conceived to accelerate decomposition mechanisms of organic matter that naturally occur in the receiving water bodies. Thus, decomposition of the the degradable organic pollutants is achieved under controlled conditions, and at smaller time intervals than in the natural systems.

The essence of secondary treatment is inclusion of a biological stage. While preliminary and primary treatments have predominantly physical mechanisms, removal of organic matter in the secondary stage is carried out through biochemical reactions, undertaken by micro-organisms.

Non-mechanised treatment systems

a. DEWATS – Decentralised Wastewater Treatment Systems

Decentralised Wastewater Treatment Systems (DEWATS) are based on the principles of decentralisation, simplicity and reuse of the treatment products. Simplicity is achieved through on-site treatment without chemicals or electro-chemical equipment/energy input, and by low maintenance requirements. Necessary maintenance activities can be carried out by service

providers or by supervised and trained maintenance personnel on-site. There are three main treatment steps & modules, which are combined and customised according to specific local conditions:

- Primary treatment (sedimentation) – anaerobic settler or biogas digester.
- Secondary treatment (biological processes) - anaerobic baffled reactor (ABR), anaerobic filter (AF), horizontal/vertical gravel filter (HGF/VGF).
- Advanced secondary treatment options.

DEWATS can treat both domestic and organic industrial wastewater and are reliable, long lasting and tolerant towards inflow fluctuations. DEWATS can be tailored to treat wastewater flows from 1 to 500 m³/day and are designed to meet the requirements stipulated by country-specific environmental laws and regulations.

Figure 21: Schematic diagram of DEWATS

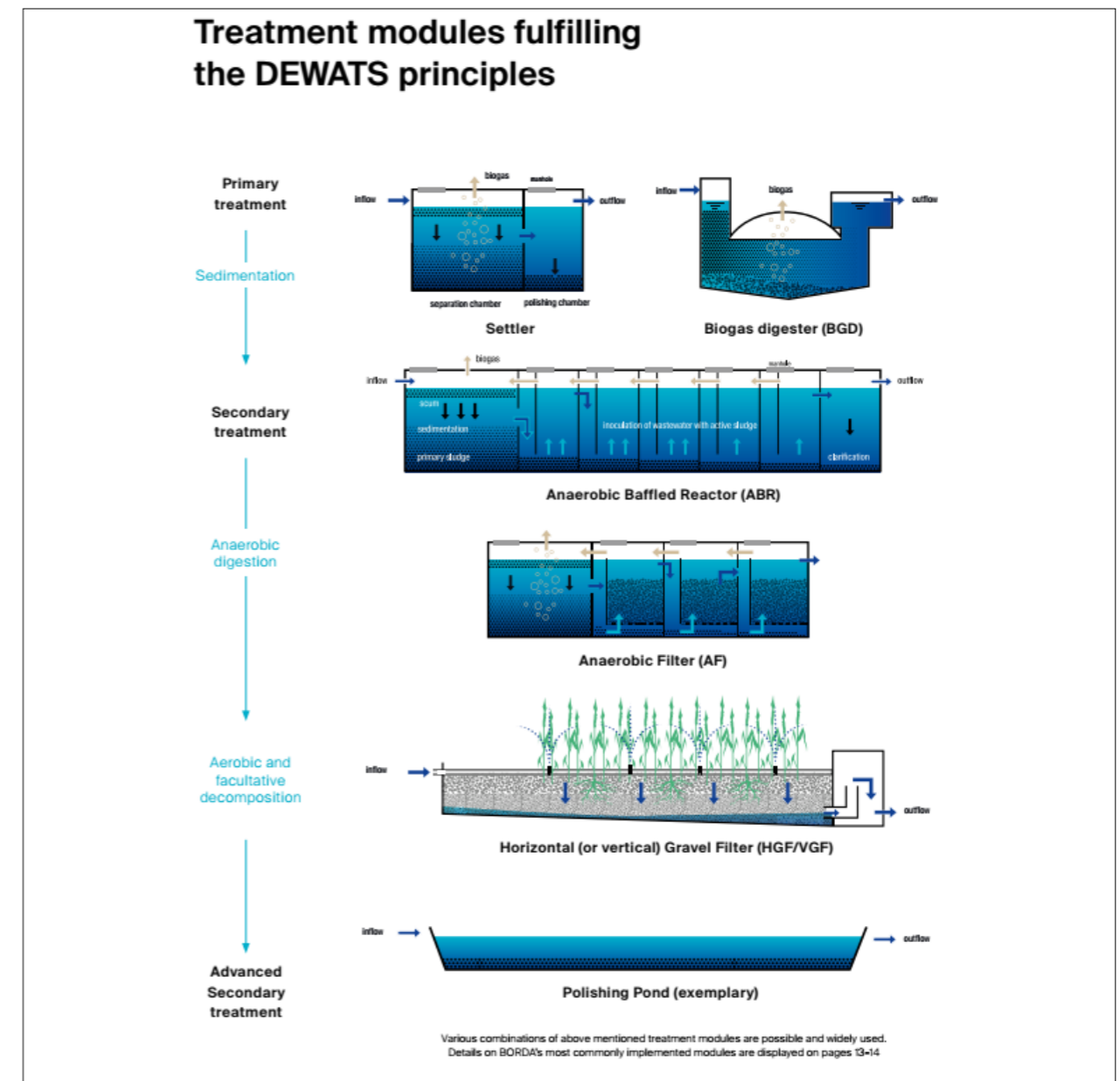

Source: BORDA, 2017

b. Waste stabilisation ponds (WSPs)

WSPs are large, man-made water bodies in which blackwater, greywater or faecal sludge are treated by natural occurring processes under the influence of solar radiation, wind, microorganisms and algae. The ponds can be used individually, or linked in a series for improved treatment. There are three types of ponds: (1) anaerobic, (2) facultative and (3) aerobic (maturation). Each pond has specific design characteristics and provides different levels of treatment. WSPs are low-cost for O&M and provide a higher degree of BOD and pathogen removal. However, WSPs require a large surface area and careful design under the guidance of experts. The effluent still contains nutrients (e.g. N and P) and is therefore appropriate for the reuse in agriculture, but not for direct discharge in surface waters.

Figure 22: Schematic diagram of a waste stabilisation pond (WSP)

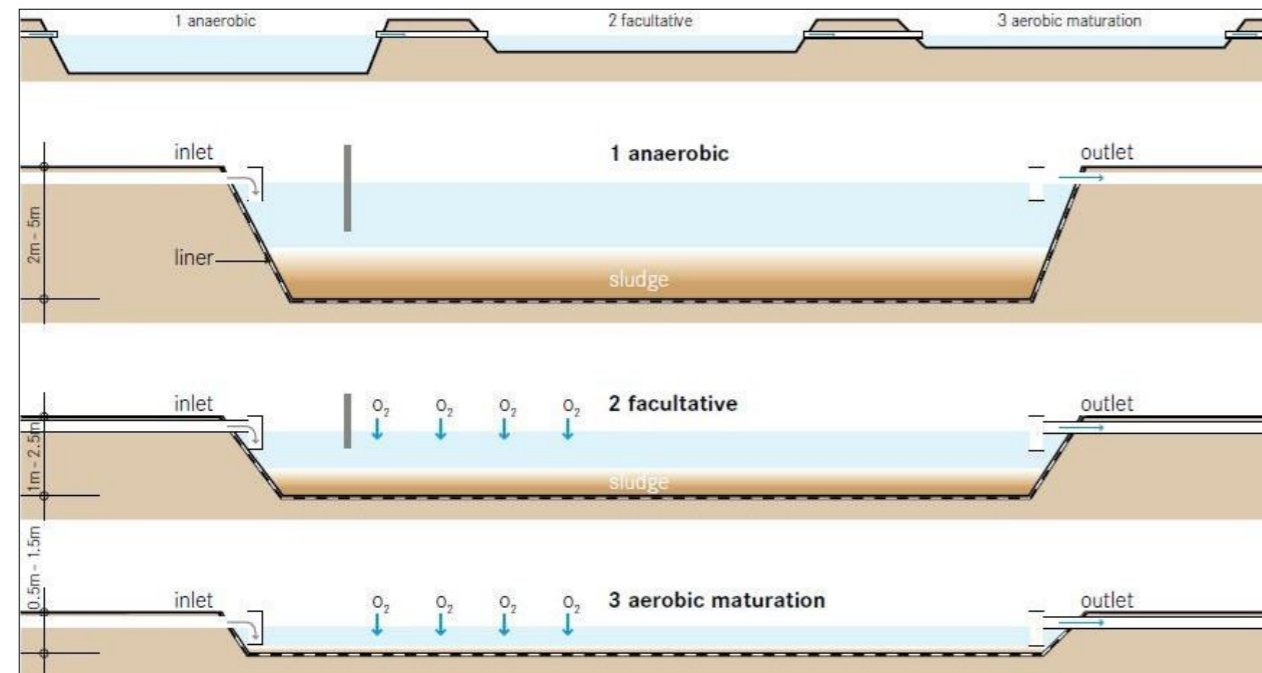

Source: Tilley et al., 2014

In the first pond (anaerobic pond), solids and settleable organics settle at the bottom forming a sludge, which is digested anaerobically by microorganisms. In the second pond (facultative pond), algae growing on the surface supply oxygen to wastewater leading to both anaerobic digestion and aerobic oxidation of the organic pollutants. Due to the algal activity, rise in pH leads to inactivation of some pathogens and volatilisation of ammonia. The last pond acts as a retention basin for stabilised solids and inactivation of pathogenic microorganisms via heat, rise in pH, and solar disinfection.

Almost all wastewater (including heavily loaded industrial wastewater) can be treated, but higher the organic load, higher is the required surface area. In the case of high salt content, use of treated water for irrigation is not recommended. A WSP designed for 20-60 day HRT results in a good treatment resulting in 90% BOD and TSS removal, high pathogen removal and relatively higher degree of ammonia and phosphorus removal.

c. Soil bio-technology (SBT)

SBT is a groundwater treatment system based on the trimming filter principle. In this system, suspended solids, organic and inorganic contents in the wastewater are removed using a combination of physical processes such as sedimentation, infiltration and organic processes.

The key components of a SBT system include an adequate mineral structure, a culture with native microflora, and bio-indicator plants. It is also known as constructed soil filter (CSF). RCC, stone-masonry or soil bundles are built into SBT systems. It includes a raw tank, a bioreactor container, a water tank, piping, and pumping systems.

Figure 23: Schematic diagram of a SBT system

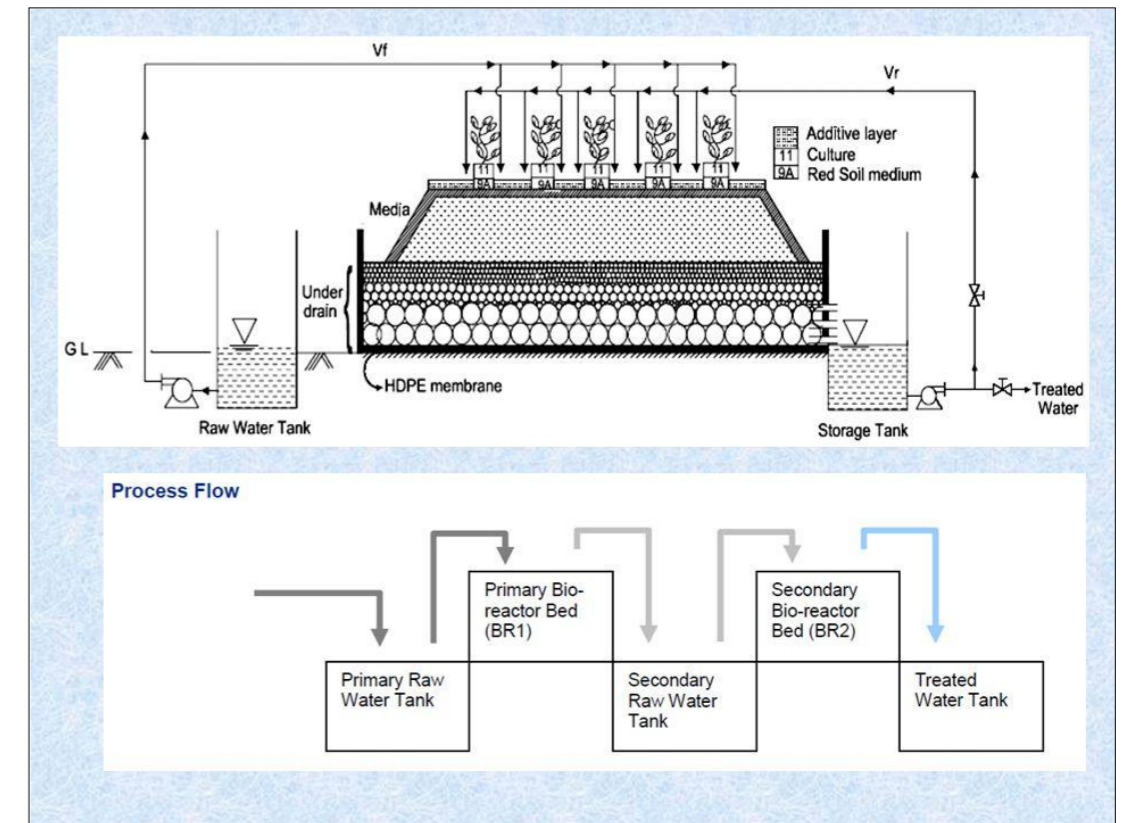

Source: www.sugam.in

Mechanised treatment systems

a. Activated sludge process (ASP)

Aerobic suspended growth systems are of two basic types, those which employ sludge recirculation, viz., conventional activated sludge process and its modifications and those which do not have sludge recycle, viz., aerated lagoons. In both cases, wastewater containing organic matter is aerated in an aeration basin wherein micro-organisms metabolize the soluble and suspended organic

matter. Part of the organic matter is synthesized into new cells and part is oxidized to carbon dioxide and water to derive energy. In activated sludge systems, the mixture of new cells and old, dead cells formed as a result of biological processes is called activated sludge. The activated sludge is present in suspension with wastewater and it is separated in a clarifier or a secondary settling tank provided in succession to an aeration basin. Since this sludge contains new cells, a part of it is recycled back to the aeration basin while remaining portion forms the waste or excess sludge. In case of an aerated lagoon, the microbial mass leaves via effluent stream or may settle down within aeration basin due to insufficient mixing.

Figure 24: Schematic diagram of ASP

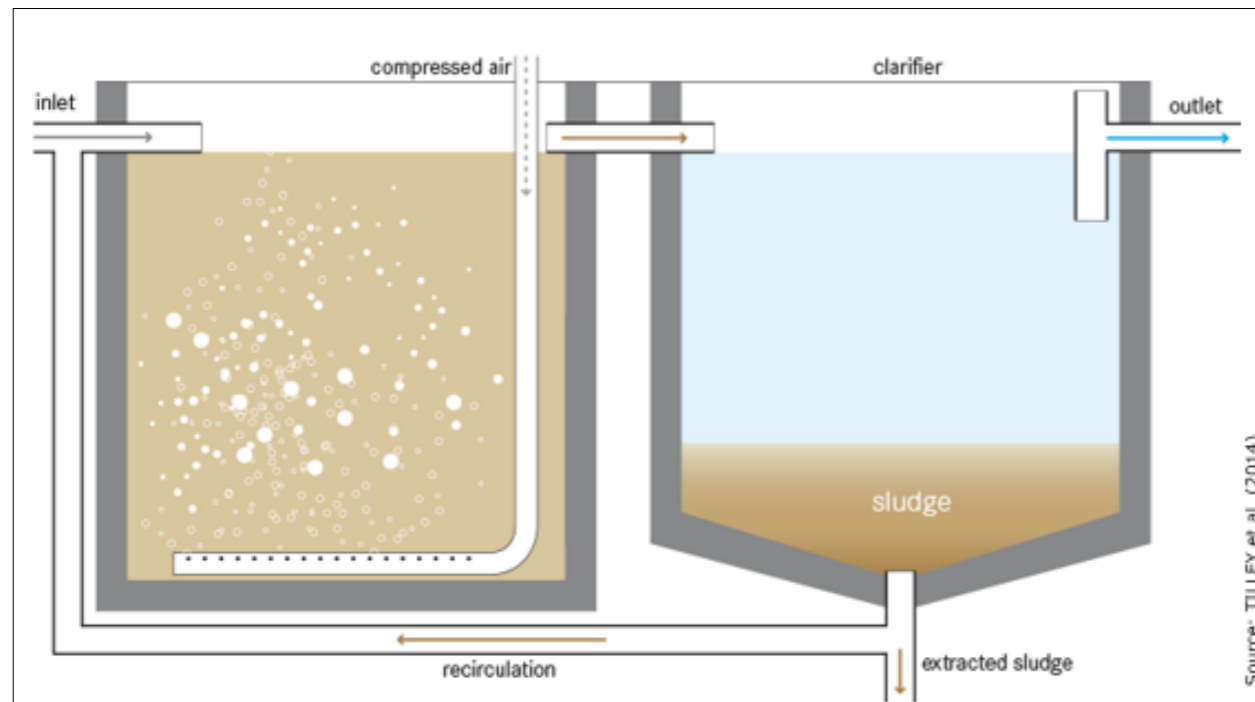

Source: Tilly et al, 2014

The suspended solids concentration in the aeration tank liquor, also called mixed liquor suspended solids (MLSS), is generally taken as an index of the mass of active micro-organisms in the aeration tank. However, the MLSS will contain not only active micro-organisms but also dead cells as well as inert organic matter derived from the raw wastewater. The mixed liquor volatile suspended solids (MLVSS) value is also used and is preferable to MLSS as it eliminates the inorganic matter. The conventional activated sludge treatment system usually consists of a primary clarifier/primary settling tank, an aeration tank, a secondary clarifier/secondary settling tank, a sludge return line and an excess sludge waste line leading to a sludge digester. The removal of organic pollutants in the activated sludge process is about 85% to 92% measured in terms of BOD.

b. Sequential batch reactor (SBR)

The SBR is similar to the ASP in terms of functional process scheme. The only difference between these processes are the treatment units provided in their respective design. In an ASP system, the wastewater will sequentially and continuously flow through a primary clarifier, an aeration tank and a secondary clarifier. On the other hand for SBR process, the aeration and settling are carried out in batch mode one after the other. Also, these two processes occur in the same tank. A primary clarifier is usually not provided in a wastewater treatment plant having a SBR. It is advisable to have at least two SBR units operating in parallel so that when one is in the aeration

phase, the other can be in the settling and decanting phase. Due to the different operational phases, the SBR is called a batch-mode system while the activated sludge process is referred to as a continuous flow system. Moreover, comparing the footprint on a like-to-like basis, the SBR system mentioned here will have a higher area requirement against an activated sludge system.

SBRs are typically configured and operated as multiple parallel basins. It includes an instrumental control system that regulates timed sequences for filling, reaction, settling and effluent decanting. All these are referred to as one cycle of process control operation. It is the time duration between successive decanting sequences during which liquid level moves from a lower water depth (bottom water level) to its fill depth (top water level) and back to its lower water depth (bottom water level). This volume progression takes place in repetitive sequences that permit reactive filling to be followed by solid-liquid separation.

Figure 25: Schematic diagram of SBR

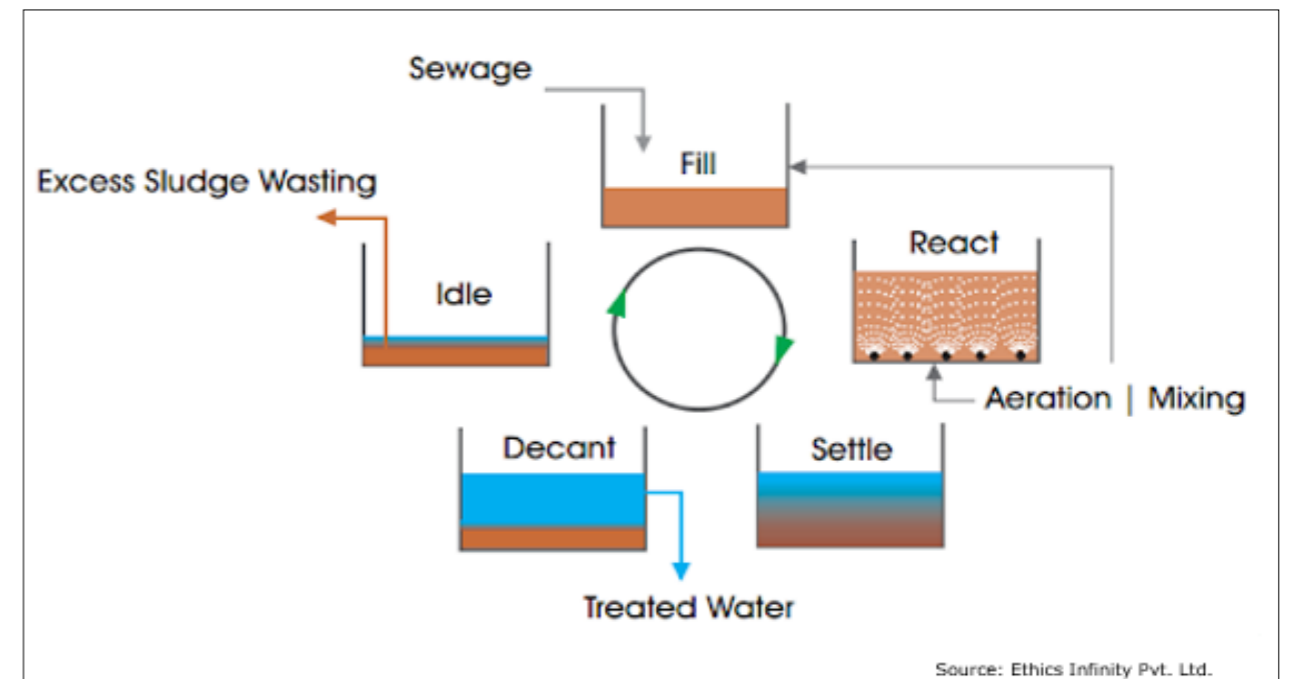

Source: Ethics Infinity Pvt.Ltd.

c. Moving bed biofilm reactor (MBBR)

MBBR is based on the biofilm carrier elements. Several types of synthetic biofilm carrier elements have been developed. These biofilm carrier elements are present in suspension with mixed liquor in the aeration tank. Continuous air supply is provided using air blowers and air diffusers to maintain aerobic conditions. This air supply ensures that the biofilm carrier elements do not settle down in the aeration tank. They have a tendency to accumulate in the top zones. Hence, wall mounted mixers propel the media downwards so that they again float and are in circulation in the mixed liquor. They are retained by suitably sized sieves at the outlet.

The provision of biofilm carrier elements aids in increasing the biomass concentration for a fixed basin volume. Hence, MBBR process acts as an improved ASP system with smaller aeration basin volume requirements. They have also been used to improve the volumetric nitrification rates and to accomplish the denitrification in aeration tanks by having anoxic zones within the biofilm depth. Because of process complexities and issues related to understanding biofilm area

and activity, the process design is empirical. There are now more than 10 different variations of the processes in which a biofilm carrier material of various types are suspended in the aeration tank. There are many examples of such activated sludge treatment process with suspended biofilm carrier in the world.

Figure 26: Schematic diagram of an activated sludge process having a moving bed biofilm reactor; MBBR media used to provide extra surface for biological growth of aerobic microorganisms

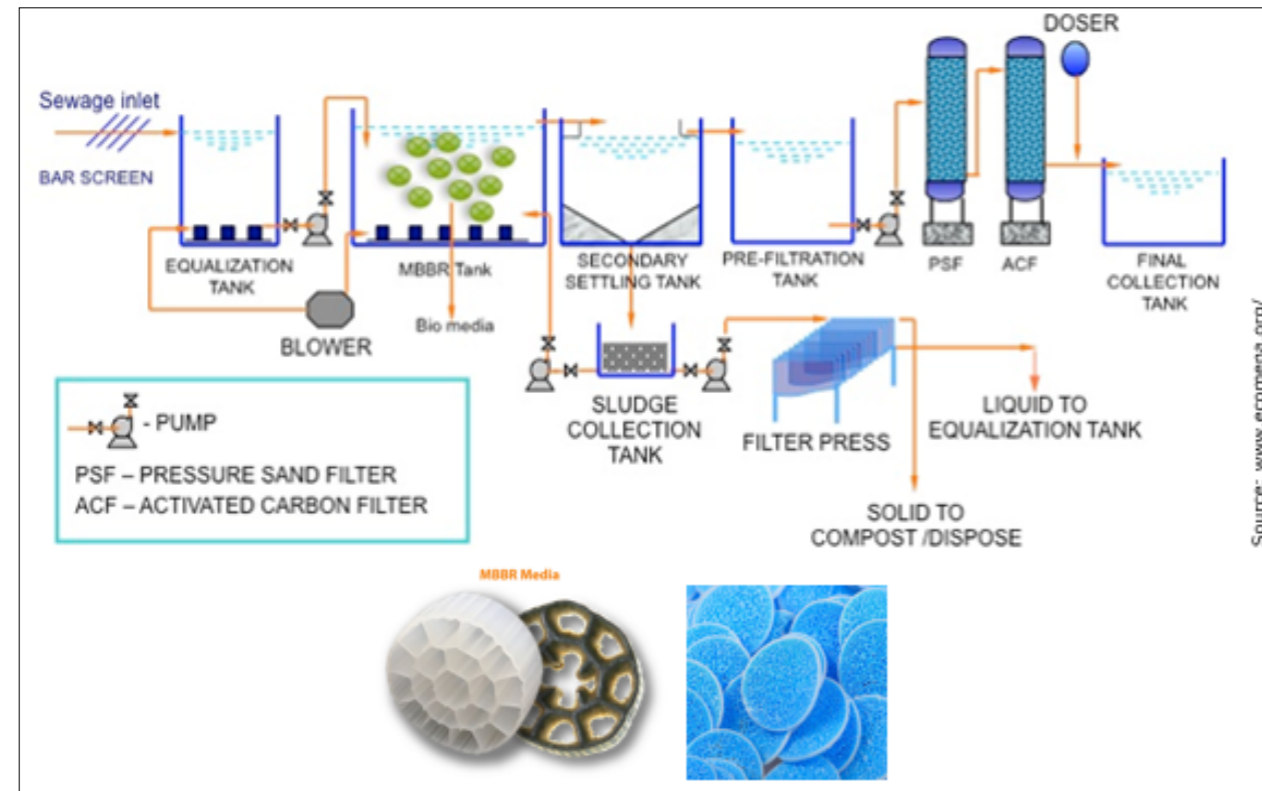

Source: www.ecomena.org

d. Membrane bio-reactor (MBR)

The membrane bioreactor (MBR) process is a combination of activated sludge process and membrane separation process. Low pressure membranes (ultrafiltration or microfiltration) are commonly used in a MBR system. Membranes can be submerged in the aeration tank or placed in a separate tank or compartment and are used for solid-liquid separation by filtration instead of the usual settling process in a settling tank. The influent is pre-treated and screened before it enters the membrane bioreactor tank wherein biodegradation of organic matter takes place. The mixed liquor is withdrawn by water head difference or suction pump through membrane modules in a reaction tank, being filtered and separated into biosolids and liquid. Membrane surface is continuously washed during operation using liquid mixed with air supplied through air diffusers installed at the bottom of reaction tank. During this washing process, biosolids filtered on the membrane surface is collected as sludge. This sludge is removed from the reaction tank using a dedicated sludge pump. Permeate collected as filtrate after membrane separation is the treated effluent.

Figure 27: Schematic diagram of MBR

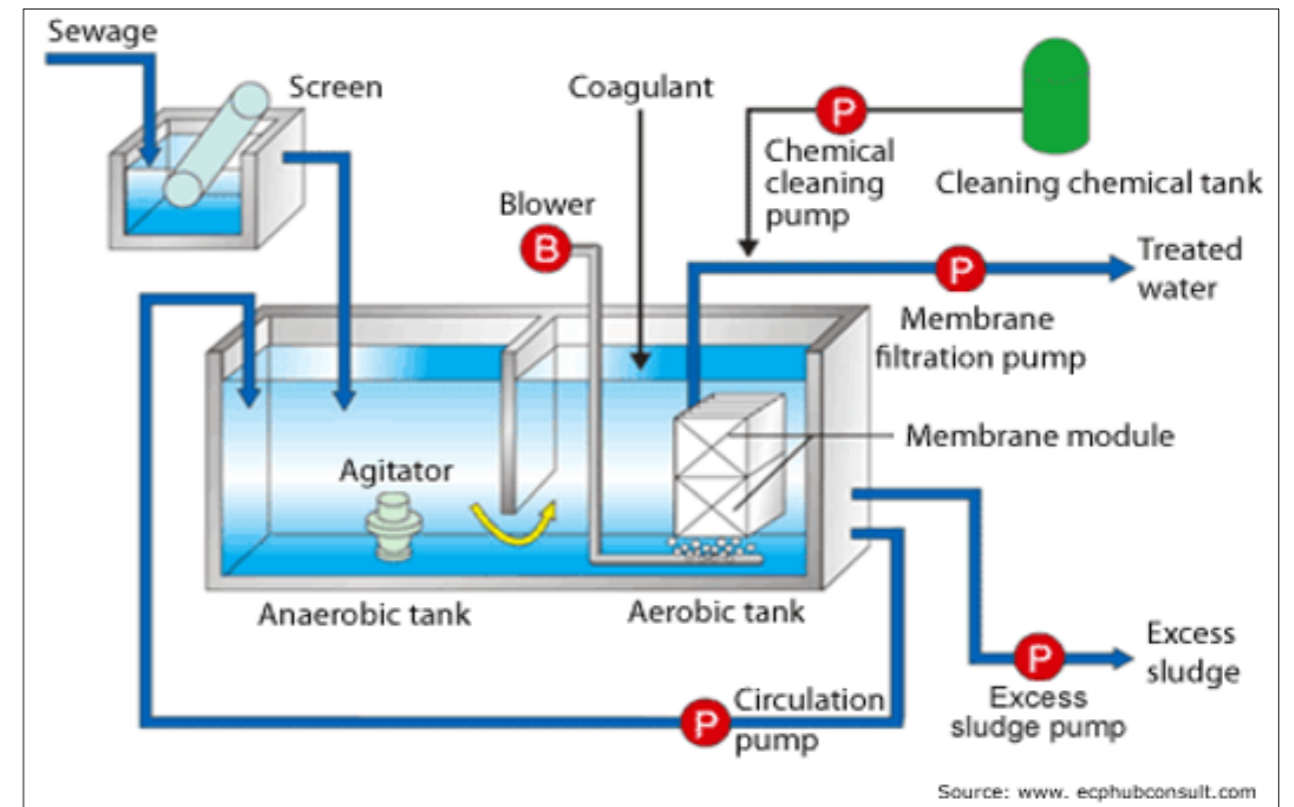

Source: www.ecphubconsult.com

D. Tertiary treatment

a. Chlorination

The destruction, inactivation, or removal of pathogenic microorganisms can be achieved by chemical, physical, or biological means. Due to its low cost, high availability and easy operation, chlorine has historically been the disinfectant of choice for treating wastewater. Chlorine oxidises organic matter, including microorganisms and pathogens. Major concerns with chlorination are about harmful disinfection by-products and chemical safety. However, chlorination as the choice for disinfection of wastewater has been increasingly replaced by alternatives such as ozonation (O_3) and ultraviolet (UV) radiation technologies.

Figure 28: Chlorination basin (left); a schematic diagram of chlorine dosing with mixer (right)

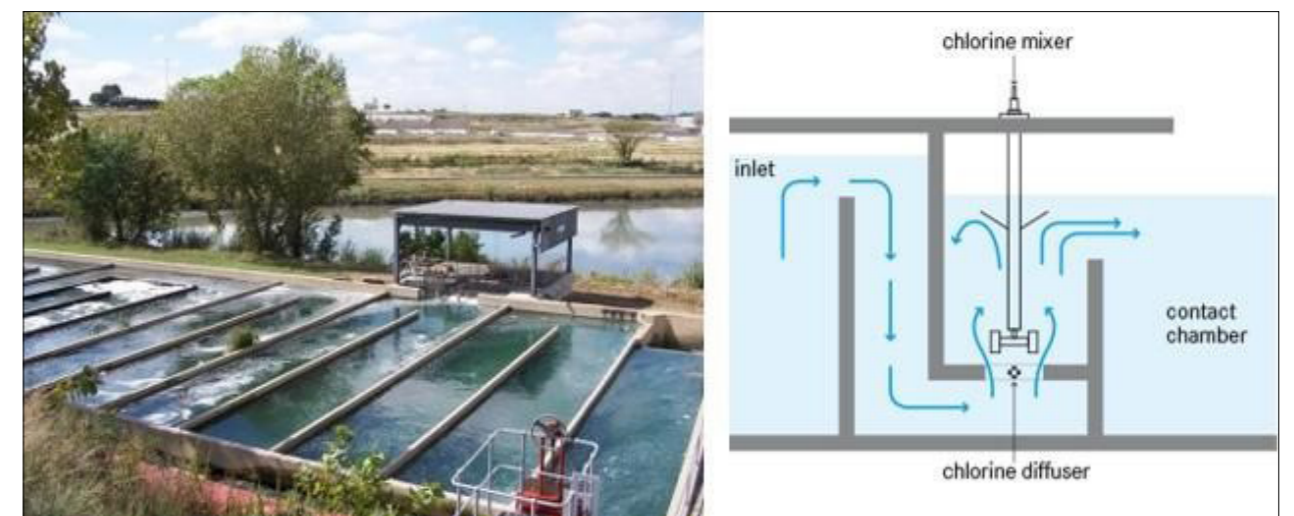

b. Ozonation

Ozonation is an efficient disinfection process to reduce the amount of micro-pollutants released in the aquatic system by wastewater treatment plants. Although no residual by-products are generated by ozone itself, some concerns are raised regarding oxidation by-products when water containing both organics and ions, such as bromide, iodide and chlorine ions, are treated with ozonation. A typical ozonation system consists of an ozone generator and a reactor where ozone is bubbled into the water to be treated as shown below.

Figure 29: Schematic diagram of ozonation

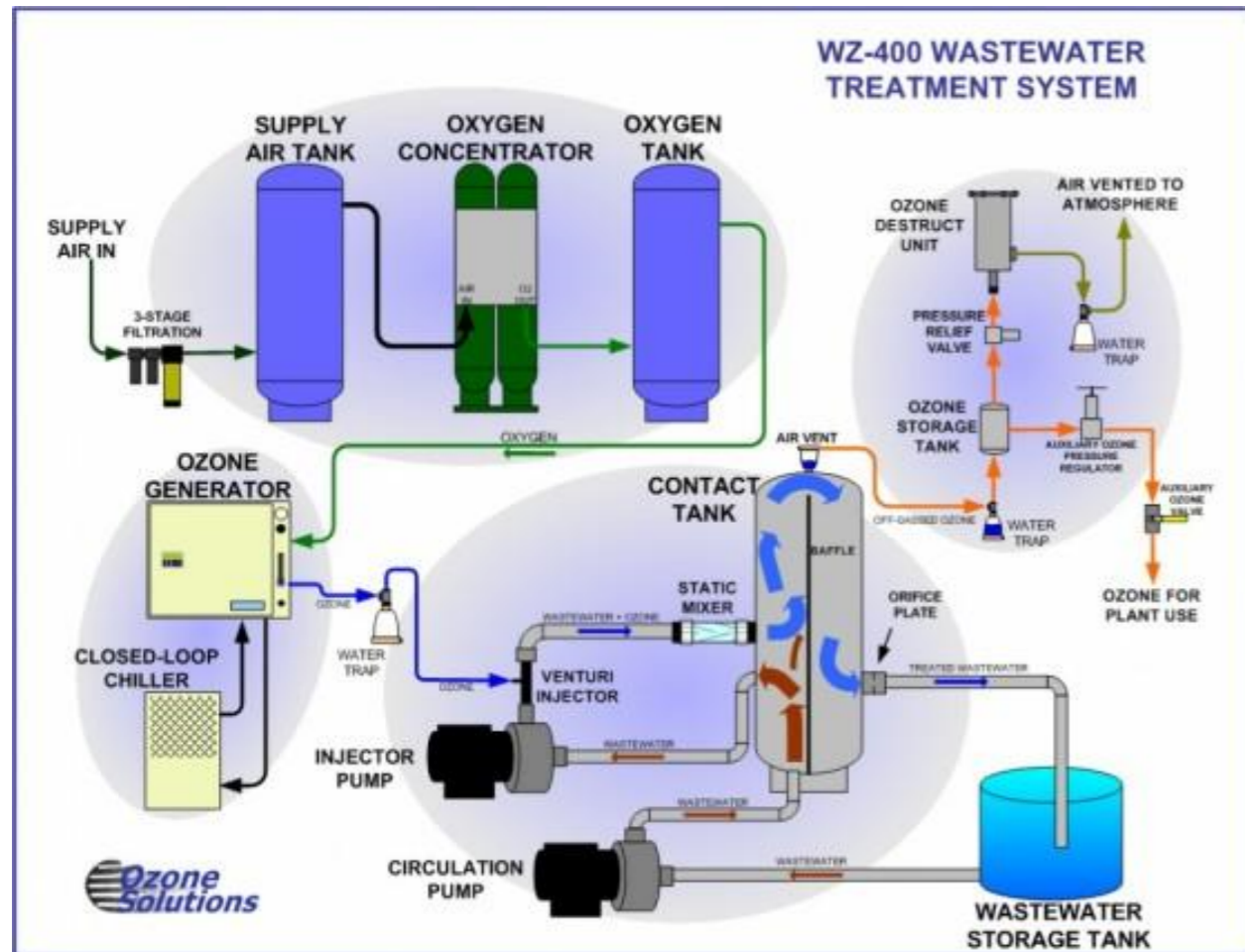

Source: Ozone Solutions

c. UV Disinfection

An ultraviolet (UV) disinfection system transfers electromagnetic energy from a mercury arc lamp to the genetic material (DNA and RNA) of pathogens. When UV radiation penetrates the cell wall of a pathogenic organism, it destroys the cell's ability to reproduce. The effectiveness of UV disinfection is dependent on wastewater characteristics, intensity of UV radiation, time period for which microorganisms are exposed to radiation and reactor configurations.

Figure 30: Schematic diagram of UV disinfection system

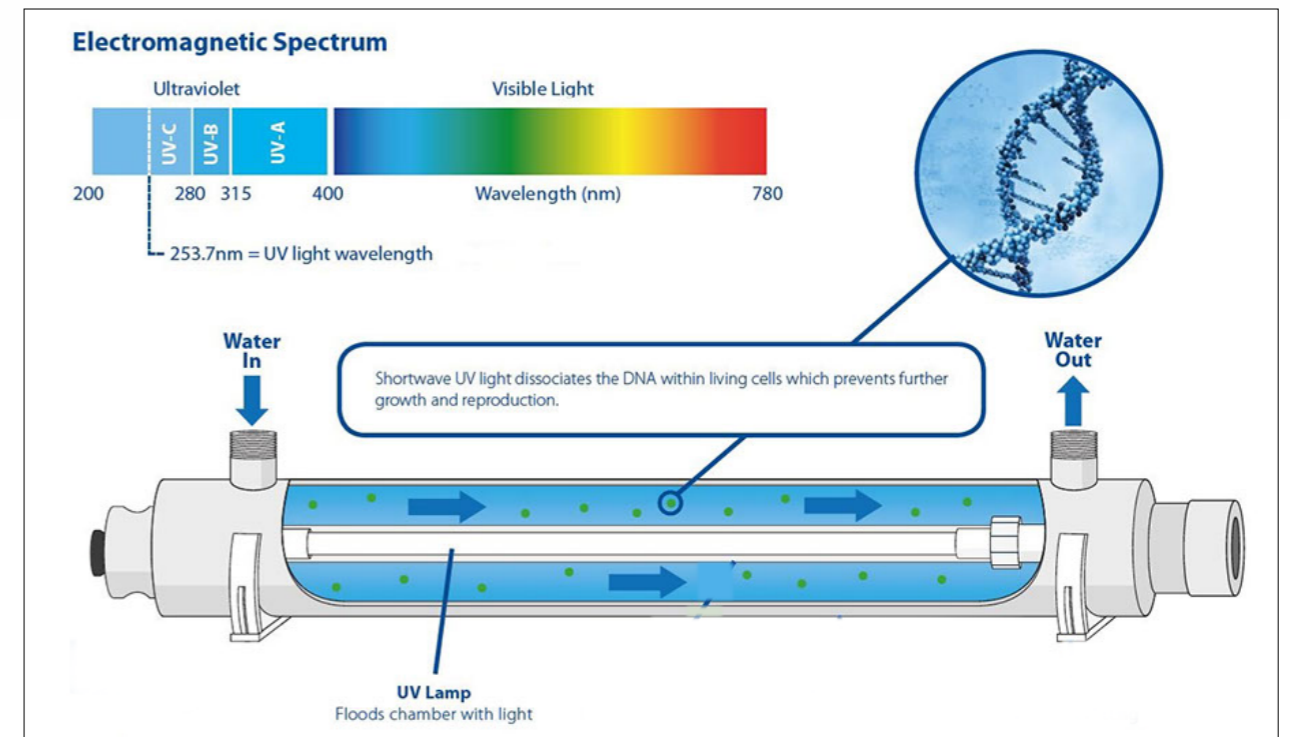

Source: www.alfauv.com

5.4.4 Co-treatment of faecal sludge and septage (FSS)

The similarity in the characteristics of FSS & sewage makes co-treatment an attractive method of FSS treatment and disposal. However, appropriate facilities are needed at wastewater treatment plants to receive, pre-treat & distribute the FSS into appropriate process units. FSS, which may be considered as a high strength wastewater can be either dumped into an upstream sewer or added directly into various unit processes in a wastewater treatment plant. In both cases, it is essentially a slug load of concentrated waste resulting from unloading of FSS by vacuum trucks.

The ability of a wastewater treatment plant to accommodate FSS depends on the following factors:

- Plant type, layout and location
- Plant design capacity
- Current wastewater flow
- Plant effluent limitations, including characteristics such as BOD, suspended solids, nitrogen & phosphorus
- FSS receiving and pre-treatment facilities
- Sludge handling facilities and ultimate sludge disposal practices

The quantity of FSS that a plant can handle is governed by two major factors: 1) quantity and nature of the flow; and 2) aeration capacity and solids handling capacity of the wastewater treatment plant. The volume of FSS relative to sewage is important since it determines the organic solids load applied to a wastewater treatment plant where co-treatment is implemented. The amount of FSS load that can be applied on treatment units processes are significantly influenced by the nature of the flow of FSS, which could be in the form of either a slug load or a continuous load.

In general, when FSS is fed as a slug load to aeration basins in wastewater treatment plants, the FSS load applied should be about half of that applied under continuous loading conditions. FSS is about 50 times as concentrated as domestic sewage in terms of organic & solids loading.

Addition of FSS for co-treatment

There are two options for treating FSS in a wastewater treatment plant. It could be treated either as a part of the liquid stream or as part of a solid handling and treatment system. The points of FSS addition in a typical wastewater treatment plant is shown as follows:

Figure 31: Points of FSS addition in a typical wastewater treatment plant

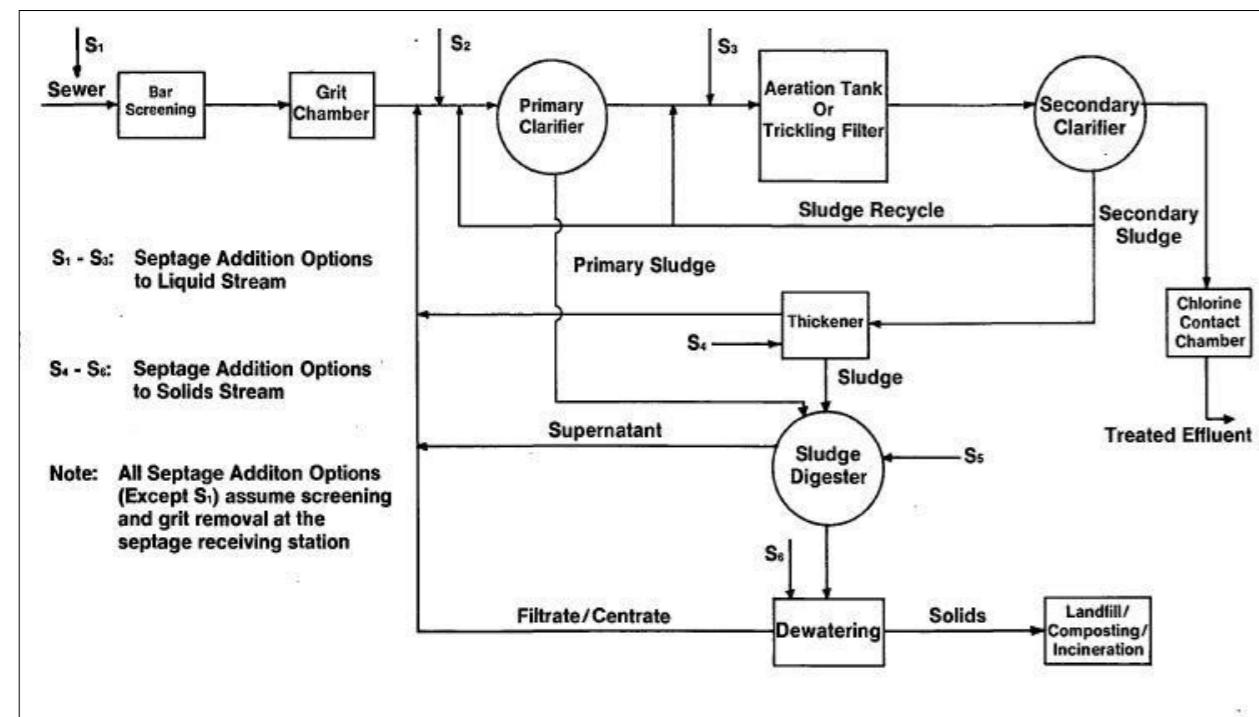

(Source: Handbook of septage treatment and disposal, USEPA)

Addition to liquid stream

FSS after preliminary treatment can be added to the liquid stream of a wastewater treatment plant at several points as shown in Figure 26. FSS may be discharged directly from vacuum trucks in slug loads, or it can be gradually fed into the system using some form of equalisation. The point of addition chosen must take into account a variety of factors, not the least of which are locations of plant bypass lines, organic and hydraulic loadings (design and actual), physical capacity of unit processes directly and indirectly affected by septage addition.

Addition to solid (sludge) stream

FSS addition to the solid stream may be made either at the thickening stage, digestion stage or dewatering stage. This would mainly depend on the incoming FSS characteristics. Faecal sludge has solid content which is comparable to sewage sludge. Faecal sludge can be added to the sludge thickening stage which causes an increase in solid content of the sludge. The sludge is further sent to the digestion stage. Since the solids are faecal sludge and organic in nature, they contribute to production of methane in the digester. The biologically stabilised faecal sludge will now have characteristics very similar to the septage. Septage, which undergoes certain degree of stabilisation in the containment unit, has good dewaterability and hence, can be directly sent to the dewatering stage.

Impact of FSS Addition

- G. Smaller wastewater treatment plants are more prone to facing severe issues pertaining to hydraulic loading. A tanker load of FSS can lead to increase in hydraulic load to the primary clarifier and aeration tank. Retention time of both the components will get reduced for a specific duration. The solid removal efficiency will reduce in the primary clarifier and these excess solids will reach the secondary treatment unit. In the secondary treatment unit such as aeration tank, higher solids will cause higher oxygen requirement for digesting the organic solids. This is only possible if the aeration unit has buffer capacity. Retention time of aeration tank will also be reduced and as a result of this, effluent from secondary treatment will not meet the desired treatment efficiencies.
- H. Increased organic load to biological treatment units hampers the efficiency of treatment. The effluent from these units do not meet the design values and may also hamper subsequent treatment steps.
- I. If the receiving station is not monitored and industrial sludge of septage containing toxic substances is introduced, then the microbial balance of biological process gets hampered. Toxic substances change the pH of reactors and microorganisms are susceptible to the pH. Thus, the efficiency of biological treatment decreases and revival of it takes a considerable amount of time.
- J. Odour and foaming problems occur in case of slug loading. Due to shock load, there are chances that septic conditions are created. This leads to problems related to odour and foaming.
- K. Co-treatment of FSS with sewage surely impacts generation of sludge in the clarifiers. Primary sludge will now have a higher percentage of organic content. Increase in sludge quantities will affect the sludge treatment chain. In case of sludge handling capacity without any buffer capacity, it will create a major challenge for treatment plant operator. Both digestion and dewatering of bio-solids will be hampered. In case of an anaerobic digester, there are high chances of the digester content having low pH levels due to excessive acid formation. However, in case of aerobic digesters, the BOD removal efficiency increases.
- L. If fat, oil and grease (FOG) is not removed during pre-treatment of raw FSS, then issues related to scum buildup will arise in clarifiers.
- M. Due to increase in sludge production, there will be an increase in solid loading rate of sludge treatment units. Septage inherently takes time to thicken as compared to sewage sludge causing the sludge thickening process to slow down. The dewatering unit is usually designed for a certain solid loading and increase in solid loading causes the dewatering unit to operate continuously. This leads to frequent mechanical wear and tear. However, the efficiency of dewatering increases.
- N. Finally, if the liquid treatment chain gets affected, there are high chances that the treated effluent violate discharge norms does not meet the discharge norms set by the concerned pollution control authorities. Such situation should not be allowed to arise as reviving plant performance to meet the discharge norms is difficult, cost intensive, and time-consuming process. The increase in the pathogen levels can be catered to by increasing the chlorine/ozone dosing or increasing the intensity of UV disinfection equipment.

5.5 Notes for trainer

The aim of this session is to introduce the participants to various treatment technologies available in the market. Use of audio-visual aids is recommended while explaining the functioning of technologies. Applicability of treatment technologies depending on the changing criteria should be explained. Emphasis should be given on illustrating the choice of technology through suitable examples.

5.6 Bibliography

Dorai Narayana (2020), Co-treatment of septage & faecal sludge in sewage treatment facilities, International Water Association (IWA).

United States Environmental Protection Agency (US EPA's), Handbook Septage Treatment & Disposal

Linda Strande, Mariska Ronteltap and Damir Brdjanovic (2014), Faecal Sludge Management-Systems approach for implementation & operation, International Water Association (IWA)

Marcus Von Sperling (2007), Wastewater characteristics- treatment & disposal, International Water Association (IWA)

Session

06

Planning for co-treatment of faecal sludge and septage with sewage

6. Planning for co-treatment of faecal sludge and septage with sewage

6.1 Session objectives

- A. Get familiar with the steps involved in planning and scaling up of co-treatment of faecal sludge and septage with sewage at an STP.
- B. Understand the impact of unscientific addition of faecal sludge and septage in a sewerage network.
- C. Learn about the administrative controls required for a smooth implementation of co-treatment at an STP.

6.2 Session plan

Duration- 60 minutes

Activity	Time	Material/Method
Planning of co-treatment	10 min	Powerpoint presentation
Adding sludge in sewerage system	10 min	Powerpoint presentation
Administrative controls	10 min	Powerpoint presentation
Q & A	10 min	Discussion
Part C: Exercise 3 – Pre feasibility assessment	20 min	Exercise

6.3 Key facts

- D. Planning of co-treatment needs mapping of sewerage appurtenances, detailed data collection and analysis.
- E. Unscientific addition of faecal sludge and septage can affect the functioning of sewerage systems and its appurtenances such as pumping stations.
- F. Administrative controls are as important as the engineering controls in case of co-treatment.
- G. While performing co-treatment, monitoring and checks need to be performed at various stages.

6.4 Learning notes

6.4.1 Planning for co-treatment

When planning for co-treatment, certain information/data should be available for assessment of technical feasibility of co-treatment. In the absence of reliable data, appropriate conservative figures may be estimated or adopted from literature for planning purposes.

Table 6 provides the list of data pertaining to STP which will be required for carrying out the technical feasibility of co-treatment. Points 1 to 4 consist of basic data which can be used to determine the feasibility of co-treatment. This would be sufficient for planning for co-treatment at a regional scale. However, detailed assessment data in point 5 will be required.

Table 8: Characteristics of the STP where co-treatment is being proposed

Sr. No.	Parameters	Details
1	Size of STP	Should be sufficient to mitigate shock loadings from tanker discharge volumes, or alternatively, justifiable to allow investment on reception facility, screening/grit removal, blending/mixing and possibly solids/liquid separation
2	Spare capacity	This is expected to be available for planning period to accommodate the sludge to be co-treated
3	Regulated effluent standards	They should be regulated for (BOD, COD, SS, N, P, coliforms, others)
4	Current STP effluent performance	(BOD, COD, SS, N, P, coliforms, others). The STP should be meeting the effluent standards.
5	Key process design parameters	Includes sizing, retention times, surface overflow rates, oxygen supply, mixed liquor volatile suspended solids (MLVSS), food to microorganism ratio, sludge age, equipment ratings and STP sludge handling capacity

Table 7 provides the list of data required with regards to the sewer network leading to the STP. This helps to assess the duration for which co-treatment would be possible at the STP and to gauge the economic feasibility of investing in making changes at the STP. The network maps providing information related to appurtenances of the sewerage and sewage pumping stations is also helpful for identifying the opportunities of co-treatment.

Table 9: Characteristics and future prospect of the catchment of STP

Sr. No.	Parameters
1	Current sewage flows (daily, peak)
2	Projection of sewage flows over planning period
3	Characteristics of sewage and expected changes in planning period

Table 8 gives a list of data regarding the quantity and quality of faecal sludge and septage to co-treated at the STP. The points 1 and 2 is critical for planning of co-treatment in the initial stage. However, for carrying out detailed assessment of the technical feasibility of co-treatment, data marked in points 3 and 4 would be required.

Table 10: Characteristics and future prospect of the incoming FSS to be co-treated at the STP

Sr No.	Parameters
1	Projection of sludge flows over planning period
2	Source of sludge (pits, septic tanks, containment vaults, community toilets, etc) with respective quantities
3	Total estimated sludge to be treated (annual, daily, hourly)
4	Characteristics of sludge and projected changes expected in planning period

A. Identifying opportunities for co-treatment

For co-treatment of FSS with sewage, the complete overview of sewage management infrastructure needs to be taken into consideration. The two key elements i.e. sewerage network and the STP have to be considered while planning for co-treatment. The sewerage network comes into consideration in the collection and transport stage of a sewerage sanitation system whereas the STP comes into consideration during treatment stage.

Sewerage network

In a sewerage network, there are multiple elements such as – sewer pipes, junctions (commonly known as manhole chambers), lift stations and sewage pumping stations. For the purpose of co-treatment, sewage pumping stations are of primary importance along with manhole chambers in some cases.

For studying for a sewerage network, the sewerage map is mainly required. Using the sewerage map one can know the catchment area or sewerage zones, location of the lift stations, and sewage pumping stations (SPS). This information plays a critical role during the planning stage of a co-treatment project. The specific data pertaining to each sewage pumping station is documented, clearly outlining the design capacity, the schematic diagram and list of electro-mechanical components installed with the details mentioned (both in tabular format and drawings in annexures). Alternatively, such data can also be seen in the detailed project report (DPR). Selection of SPS for further investigation can be done based on this information.

The selected SPS should be investigated in detail. First and foremost, layout of the SPS should be checked. The layout should be such that a receiving station can be constructed for receiving trucks carrying faecal sludge and septage. If this criterion is satisfied, then the design flow rate, design of grit chamber, mechanism to remove grit and screenings and the (solids handling) capacity of the pumps should be checked.

In certain cases, wherein the daily load is minimal as compared to volume of sewage, the sludge is decanted in the manholes. In such cases, identification of manholes is done using the individual catchment maps. Important details while selecting a manhole chamber are the invert levels of chamber, incoming and outgoing pipes. Additionally, the gradient of sewers will also be useful to assess the risk of decanting faecal sludge and septage with high solids content.

Sewage treatment plant

In case of STP, plant layout and surrounding areas or the main pumping station needs to be checked. If there is adequate space to accommodate a receiving station, then further investigation of the STP is recommended. While conducting a detailed investigation, schematic diagram of the treatment chain, design criteria of treatment units, and capacities of electro-mechanical components needs to be analysed. The current quantity and cost of consumables needs to be recorded. This helps to perform a cost benefit analysis and ascertain the financial viability of co-treatment. This data will be further used to make changes in the working contracts between the local government and the STP operator and avoid any risk of dispute or legal issues later on in the project.

A comprehensive checklist for collection of data at STP and SPS has to be developed and used for the detailed data collection.

Planning for co-treatment through CWIS approach

- Apart from the earlier steps for planning of co-treatment, a key step is to assess sanitation requirements of citizens, especially the unserved or underserved population like women and children, marginalized, etc.
- CWIS approach emphasises on service provision and creating an enabling environment, rather than simply focusing on building infrastructure:
 - This approach aims to pool together urban services like water supply, drainage, greywater management, and solid waste management into a comprehensive urban sanitation plan.
 - Such a comprehensive plan will bring together both infrastructure as well as non-infrastructure components including all stakeholders, strong institutional arrangements and service provisions to manage and sustain an urban sanitation system.

While planning for co-treatment involves steps to assess existing infrastructural capacity available that can be used for handling of faecal sludge and septage, it is also important to assess the ground requirements. This involves understanding the sanitation challenges faced by the people, especially women and children, marginalised communities, etc. And this is central to the idea of Citywide Inclusive Sanitation (CWIS) approach. It demands a shift in our approach to sanitation by challenging the historic approaches to this topic. It is evident that old and conventional approach to sanitation are failing to meet the rising demands of today's world. Hence, it is necessary to have new approaches for not only service provision but also in planning of sanitation services. It is important to build consensus amongst stakeholders as well as understand sanitation requirements directly from the people. Additionally, use of financial resources that are often skewed towards building sanitation infrastructure should be managed such that capacity building of sanitation workers, technical development of ground staff, outreach programs for communities, etc. also get proper attention. A balanced approach is useful to identify new and creative ways to address sanitation challenges as well as attract sustainable funding options for sanitation.

6.4.2 Adding sludge in sewerage network

The aim of gravity sewers is to transport the sewage with solids i.e. the human excreta from source to a treatment plant, where it will be treated and the end product will be reused or safely disposed of in the environment. Selecting diameter and gradient (slope of sewer) of the sewer is very critical. The sewer pipes are designed with a gradient so as to prevent solids from settling as well as attain a self-cleansing velocity of between 3 – 6 m/h. According to the CPHEEO Manual on Sewerage and Sewage Treatment Systems, it is recommended that after reaching a depth of 6 metres, a sewage pumping station needs to be set up. However, in practice, the SPS are even implemented at larger depths. To be able to function as designed, the sewerage systems need to be operated and maintained well. The usual operations include inspections and checks for breakage and intrusion of roots in the pipes. As a part of preventive maintenance to avoid clogging, use of sewer jetting machines to remove the wax and grit and rodding machines to unclog the pipes is recommended. Periodic desludging of manhole chambers is also needed to avoid clogging of chambers during the peak flow.

Often, the most convenient co-treatment solution would appear to be to discharge the sludge at sewer manholes or pump stations of the sewerage system. While this method is attractive because of convenience and logistical advantages, some of the serious consequences to be considered are given below.

Impact of sludge addition at manhole chamber

- H. Diurnal curve as shown in the Figure 27 gives the hourly variation in the volume as well as organic load in the sewerage system. From the graph, it is visible that peak hours (time when peak flow occurs in the system) are in the morning and in the evening. It can also be observed that the diurnal curves of organic and hydraulic load do not match. Hence, it is very important to understand these variations if addition of sludge needs to be done at manholes. The curves will vary for different sewer catchments (sewerage zones) in a city. Hence, for planning co-treatment in a city, the sewerage network in a specific sewerage catchment needs to be checked.
- I. Addition of sludge during peak hours in the manhole chamber might help to avoid deposition of solids in the sewers; however, this might also result in the probability of shock loading at the STP if hydraulic and organic loading diurnal curves match.
- J. Addition of sludge during the non-peak hours, might lead to deposition of solids and clogging of pipes or subsequent chambers. In such cases, during the next peak flow, some of the solids might dislodge and get carried with the wastewater. However, this results in heavy erosion of the inner walls of the pipe leading to breakage and leakage.

Figure 32: Diurnal curve - volume of sewage v/s. organic load

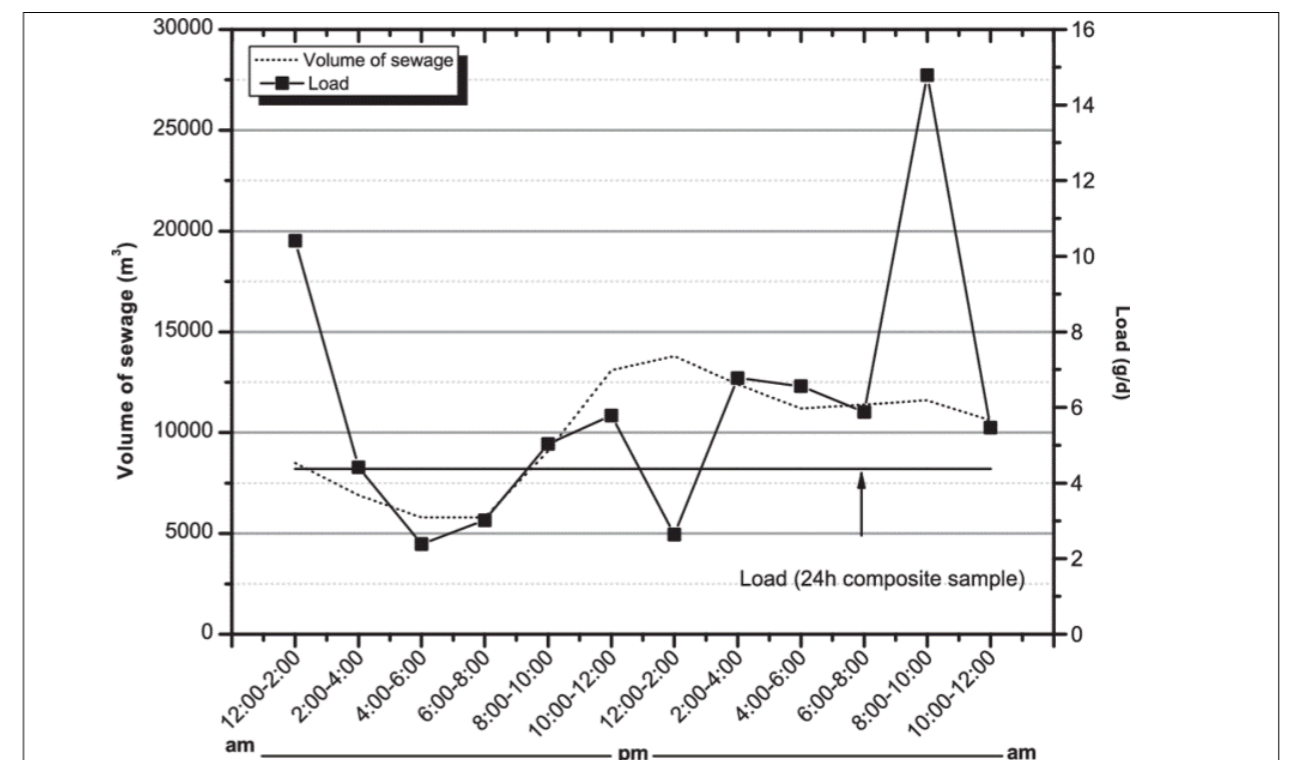

Source: Puttmann W. et al.; 2019

Impact of sludge addition at septage pumping station (SPS)

According to the CPHEEO Manual on Sewerage and Sewage Treatment System, the SPS should ideally consist of screens (preferably mechanized), grit removal chamber and pump sets for dry and wet weather flow. Grit removal is recommended, because higher amounts of grit leads to

erosion of sewer pipes (especially RCC sewer pipes are highly susceptible to erosion). Addition of sludge at the SPS be done upstream i.e. at the inlet of SPS. This ensures that the incoming sludge is screened, degrittied and then pumped along with the sewage. In cases where the sludge is added to a wet well directly, the screens and the grit chamber are bypassed and there are serious chances of wear and tear of the pumps. Although no immediate consequences are observed, the long-term impact on the operation and maintenance of such a sewerage system will be significant.

6.4.3 Administrative controls

A. Before commissioning

Byelaws or Enforcement

The state/local government should have its own FSSM policy or strategy developed which considers co-treatment as one of the approaches for FSSM. Subsequently, during the planning of co-treatment, appropriate byelaws should be drafted which will be binding for all key stakeholders in co-treatment – local government, desludging operators, STP operators and property owners. The byelaws should definitely contain the following (but not be limited to): (1) clarity on roles and responsibilities of each stakeholder, (2) standard operating procedure, (3) service indicators and benchmarks, and (4) contractual/legal implications. Currently, in many states, the desludging services are provided by private operators who are not legally or contractually bound to the local government. In few cases, they do not even have a registered business which makes it difficult to monitor them. For such irregular and informal services, a SOP with service indicators and benchmarks may bring a certain level of integrity to the business. Thus, this key information should be made available to the operators and if required an IEC campaign should be developed around it.

Paperwork or documentation

Paperwork pertaining to formal engagement with the stakeholders is necessary. This might seem like a small step in the whole process, but it makes a huge difference when it comes to mapping out the service extent and benchmarks achieved. The STP operator should opt for certification from the local government for practicing co-treatment. Co-treatment can lead to increase in secondary revenue for the operators and hence, they might be interested to opt for co-treatment at their plant. For getting the certification, an operator needs to submit details of the STP along with a strategy to manage the load coming from co-treatment. If significant changes are planned to accommodate the extra load, then the STP operator might also have to get necessary approvals before commencing co-treatment.

Licensing the desludging operator is another way to formalise any desludging services. For this, the primary documents which can be asked for are truck details, RTO registrations etc. After assessment, the license should be provided to the operators. The operators should abide any stipulated byelaws by the local government.

Characterisation of sludge

Sludge characterisation is highly recommended before the commissioning process. Sludge characteristics can vary depending on various ground conditions such as type of containment, desludging interval, climatic conditions, emptying method and dietary habits as well.

During the sludge characterisation process, the following parameters need to be checked – TSS (for designing the solid liquid separation), COD and BOD (for designing biological treatment) and nitrogen for (denitrification and nitrification treatment unit) and phosphorus.

B. After commissioning

Standard Operating Procedure (SOP)

After commissioning of co-treatment, enforcement of the respective regulations is important. The standard operating procedures (SOPs) should be developed and followed. The BIS Code or the guidelines and advisories put forward by the respective government agencies should be taken into consideration while preparing an SOP for treating of FSS. The monitoring mechanisms for keeping a check on the desludging and STP operators should be robust. SOPs are important for monitoring desludging activities by an operator, citizen engagement and other activities vital to the entire service chain. The IEC campaign around standards of operation should be carried out actively. Surprise checks should be carried out to see the adequacy of the safety and personal protective equipment and their status.

It is really important that SOP and the relevant documents are revised periodically based on the feedback taken from operators and observations made by the sanitary inspectors. This ensures that policy makers and decision makers understand the demands of the workforce and aid the improvement of their productivity levels and quality of work.

Impact monitoring

Impact monitoring at the STP is another key step once co-treatment has been commissioned. Usually, only the effluent quality is checked in a treatment plant. However, it will not provide enough information about the performance of treatment units once co-treatment is introduced. In case, when the effluent quality does not meet the standards, then it is difficult to ascertain whether the issue lies with the influent or with the performance of one or several treatment units. The sludge treatment chain is not monitored in most cases because a well-defined discharge standard for biosolids from the STP has not been developed yet. However, the biggest impact on the STP can be in the sludge stream while co-treating the faecal sludge and septage with sewage. The higher organic loading usually results in higher volume of sludge formation. Since primary and secondary sludge is mixed in the sludge treatment chain, issues can arise related to inadequate digestion of sludge and subsequently lead to reduction in dewatering efficiency.

6.5 Notes for trainer

This session contains an exercise which has been explained in PART C of this module. It is advised to solve this exercise prior to conducting this session in order to understand the pre-feasibility assessment on the planning stages for co-treatment of FSS with sewage in an STP.

The aim of this session was to inform the trainer about mapping of a sewerage network, detailed data collection and analysis required for the planning of a co-treatment system. Apart from the engineering controls, emphasis should be laid on the administrative controls, ranging from following various byelaws and paperwork to the different institutional arrangements, management and record keeping.

6.5 Bibliography

Dorai Narayana (2020), Co-treatment of septage & faecal sludge in sewage treatment facilities, International Water Association (IWA).

United States Environmental Protection Agency (US EPA's), Handbook Septage Treatment & Disposal

Marcus Von Sperling (2007), Wastewater characteristics- treatment & disposal, International Water Association (IWA)

Kevin Taylor (2018), Faecal Sludge and Septage Treatment – A guide for low- and middle-income countries.

Session

07

Septage receiving station

7. Septage receiving station

7.1 Session objectives

- A. Understand about septage receiving station - a necessary unit for safe transfer of faecal sludge and septage from a desludging equipment (such as a vacuum truck) at a treatment facility.
- B. Know about mechanised septage receiving stations which are necessary for co-treatment of faecal sludge and septage with sewage.

7.2 Session plan

Duration- 75 minutes

Activity	Time	Material/Method
Septage receiving station	10 min	Powerpoint presentation
Components of septage receiving station	10 min	Powerpoint presentation
Types of receiving station	15 min	Powerpoint presentation
Solid-liquid separation	10 min	Powerpoint presentation
Q&A with informational videos	30 min	Discussion with videos

7.3 Key facts

- C. Aim of having a receiving station is to safely transfer faecal sludge and septage to the treatment facility.
- D. Each component at the receiving station has a specific function of pre-treating faecal sludge and septage.
- E. Pre-treatment before equalisation is highly recommended.
- F. Solid-liquid separation is an important objective and helps to optimise the treatment system.
- G. Standard operating procedure should be enforced at a septage receiving station to assure proper operation by the ground staff.

7.4 Learning notes

7.4.1 Septage receiving station

The aim of a septage receiving station is to reduce the impact and risk on an STP due to co-treatment of septage and sewage. The objectives of a receiving station therefore are:

- A. It should enable safe and hygienic transfer of FSS from a hauler truck to the STP.
- B. To keep a check on O&M cost of the STP.
- C. Storage and controlled discharge (addition) FSS to the sewage.
- D. Reduce impact on the secondary stage of liquid and solid treatment chain at the STP.

While designing a receiving station, one must consider the following:

- E. Quantity of FSS to be received daily along with number of trucks to be simultaneously emptied.
- F. Design and dimensions of a desludging truck, especially the turning radius, its power to operate in reverse mode.
- G. Degree of pre-treatment for FSS. This depends on the point where FSS is mixed with sewage in a sewage network.
- H. Disposal of solid waste and grit separated from raw FSS.
- I. If the receiving station is near a residential/commercial area, odour control measures need to be provided at the receiving station.

7.4.2 Components of septage receiving station

The overall receiving station design varies with the amount of FSS to be received, design of the tank and truck, type of preliminary treatment to be provided, downstream treatment and ultimate disposal and odour considerations or requirements. There are certain design elements that are fundamental in most of the receiving stations, such as:

- Dumping station
- Screening
- Grit removal
- Storage/Equalisation.
- Odour control

A. Dumping station

Dumping station is the initial point of a septage receiving facility. It should have a ramp or a gradient to tilt the truck for complete drainage and facilitate hosing down of spillage to central drain. Hoses and other washdown equipment should be provided and should be conveniently located at the station to facilitate the clean-up by each individual hauler. FSS should be discharged through a hose extending from the rear-end of a truck to the inlet of a dumping station. The connection at the tank truck must be water-tight in order to prevent spillage and odours. The hose should be connected to a quick-release discharge tube in the dumping station to minimise spillage. It enables safe transfer of raw FSS from hauler truck to the pre-treatment components such as screens. It is important that the dumping station provides leak proof equipment for transfer of raw FSS and avoid odour nuisance. The basic layout of a dumping station is shown in the following figure.

Figure 33: Layout of a dumping station

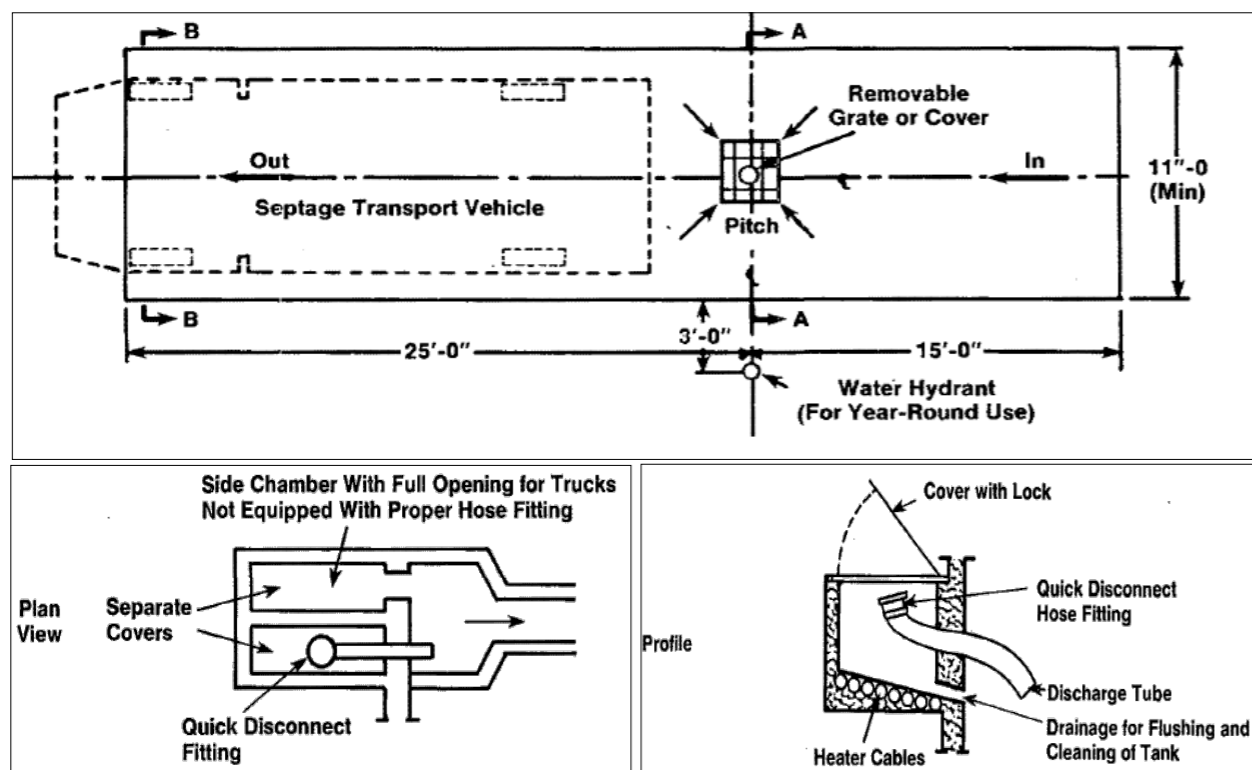

Source- US_EPA Septage treatment & disposal

B. Screening

Coarse screening options include manually raked screens, rundown screens & various types of mechanical screens, some of which also remove grit. Design parameters for coarse screen include approach velocity of raw FSS, bar width and depth, clear spacing between the bars, screen angle to the horizontal surface, and allowable head loss in the screening unit. The bar screen design calculation should be based upon the peak flow generated when a tanker discharges.

It is recommended that the screenings be dewatered in order to facilitate handling prior to disposal. Smaller treatment plants receiving FSS most often use a drained screw conveyor to transport screenings from the bar screen to a container for disposal. Presses designed for dewatering screenings are also commercially available. These presses have been used quite successfully on material from screens handling septage.

Figure 34: Design Criteria for Bar Screens

Item	Unit	Manually cleaned	Mechanically cleaned
Bar width	mm	5–15	5–15
Bar depth	mm	25–40	25–40
Clear spacing between bars	mm	25–50	15–75
Angle to horizontal	degrees	45–60	60–90
Approach velocity	m/s	0.3–0.6	0.6–1
Allowable head loss	mm	150	150

Source: Crites and Tchobanoglous, 1998

a. Prefabricated manual screens

Manual screens are used in smaller receiving stations. Usually, these screens are developed for emptying one single truck at a time. It has a 4-6 inch quick disconnect fitting which eliminates chances of spillage. The flow diverter is provided to eliminate any splashing of septage while emptying. Also, it distributes raw FSS over the screen which eliminates any instances of clogging the screen. The V-shaped screen can accommodate higher flow and is easier to rake. Solid waste removed by the screen is raked manually into a channel which has holes on its bottom surface. Thus, the waste containing some septage will also get captured and is drained in the pan below. The solid waste is then pushed into a bin or wheel barrow.

Figure 35: Picture of prefabricated manual screen



Source: Screen co systems

b. Prefabricated mechanical screens

The mechanical screens are used where human intervention needs to be completely eliminated and higher flows need to be accommodated. A 4 to 6 inch quick disconnect fitting is provided which ensures there is no spillage. These screens provide an option of stone and heavy object removal. This is followed by a shredder which shreds the solid waste such as rags, plastics etc. to appropriate size. The mechanical drum ensures that all the solid waste is arrested and disposed into the screw conveyor which washes, compacts and transfers the waste to a bin or bag.

Figure 36: Picture of a prefabricated mechanical screen



Source: WAM Group

C. Grit removal

The two-general type of grit chambers are the horizontal flow type & the aerated type. The horizontal flow type was commonly used in the past, while the aerated chambers have been found to be more effective in septage treatment applications. The grit removed from FSS can be handled in a number of ways. In certain cases, the grit is washed to retain organic solids and mix with sewage. Grit is normally hauled to the dumping areas in trucks for which loading facilities are required. In larger plants, elevated grit storage facilities may be provided with bottom gates through which the trucks are loaded.

a. Horizontal flow grit chamber

Rectangular horizontal type grit chamber is based on controlled velocity principle. The velocity is maintained close to 0.3 m/s in the channel. This provides sufficient time for the grit particles to settle down in the channel. A grit chamber is designed to remove even the lightest of grit particles in adverse conditions. They are designed to trap the particles that will be retained on a 0.21 mm diameter mesh screen. Length of the channel is determined by the depth required to settle grit particles at a certain design velocity.

Table 11: Design criteria for horizontal type grit chamber

Parameter	Unit	Range	Typical
Detention time	s	45 – 90	60
Horizontal velocity	m/s	0.25 – 0.40	0.30
Settling velocity for removal of solids:			
0.21 material	m/min	1.00 – 1.30	1.15
0.15 material	m/min	0.60 – 0.90	0.75
Headloss (as percent of depth in the channel)	%	30 – 40	36
Added length allowance for inlet and outlet turbulence	%	25 – 50	30

Source: Tchobanoglous G, et. al., 2008, Wastewater Engineering: Treatment and Reuse

b. Parabolic grit channels

Figure 37: Schematic flow diagram (left) and picture (right) of a parabolic grit chamber

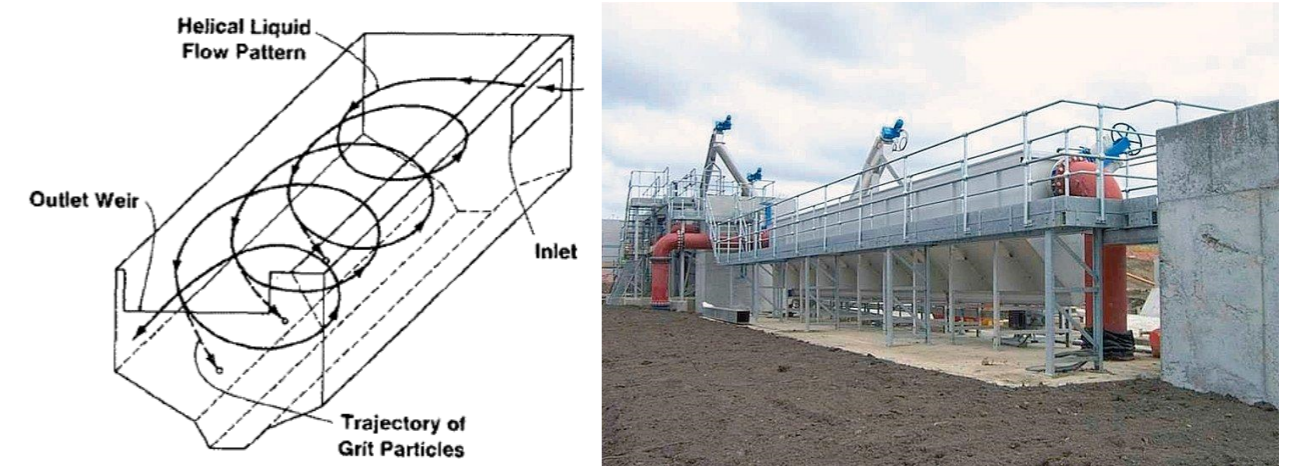

Source: Huber Rotomat Ro6

Longitudinal grit traps are used where high flows are expected. After screening, FSS moves through a helical shaped unit as shown in figure (left). During this movement, the grit settles down in the channel provided below. Aerated grit chambers are also used to improve the separation of grit from FSS. There is a screw conveyor at the bottom which collects all the grit, removes it from the chamber for washing and drying before collecting it in a bin.

Table 12: Design criteria for an aerated type parabolic grit chamber

Parameter	Unit	Range	Typical
Detention time	min	2 – 5	3
Dimensions:			
Depth	m	2-5	
Length		7.5 -20	
Width		2.5 - 7	
Width to depth ratio	ratio	1:1 – 5:1	1.5:1
Length to width ratio	ratio	3:1 – 5:1	4:1
Air supply per unit length	m ³ /m.min	0.2 – 0.5	

Source: Tchobanoglous G, et. al., 2008, Wastewater Engineering: Treatment and Reuse

c. Integrated pre-treatment module

Integrated pre-treatment module combines a mechanical screen with longitudinal grit trap. This is a single equipment which can be placed after the dumping station. Washing, and dewatering is optional and is recommended so that the solid waste and grit can be safely handled and disposed appropriately. The removal efficiency in these systems is around 90% with the particle diameter of 0.2 – 0.25 mm.

Figure 38: Integrated pre-treatment module

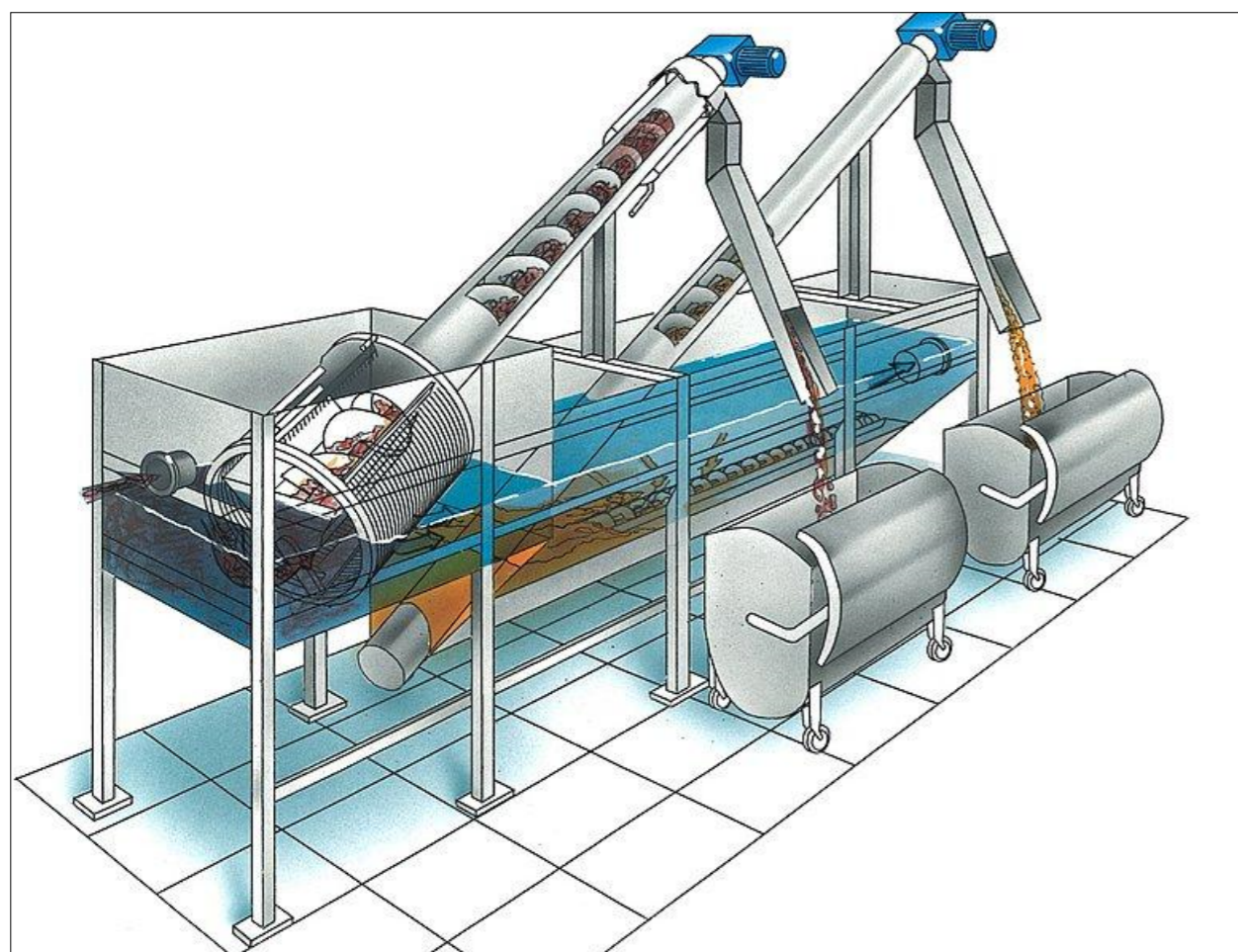

Source: Huber.de

D. Storage or equalisation

Storage or equalisation is optional but highly recommended in case of STPs which are operating at 50% or higher of their design capacity. This allows controlled addition of pre-treated septage to the liquid stream depending on the actual flow rate of domestic sewage. In certain cases, storage can also provide necessary solid-liquid separation where supernatant is pumped to the liquid stream settled sludge is pumped to the solid stream of STP.

E. Odour control systems

In case of multiple dumping stations and storage units without an aeration unit, raw FSS will often cause odour nuisance. Therefore, an odour control unit needs to be placed. Odour control can be done using chemical scrubbers, filter combustion, biological processes etc. One such commonly used unit is an activated carbon filter.

Activated carbon filters do not destroy the odour compounds, but only retain them until the carbon becomes saturated. Depth of the carbon bed must be sufficient to assure complete odour removal and to provide excess capacity. Recommended range for depth is 45 cm to 90 cm in order to achieve maximum removal efficiency.

Figure 39: Activated carbon filter for odour control

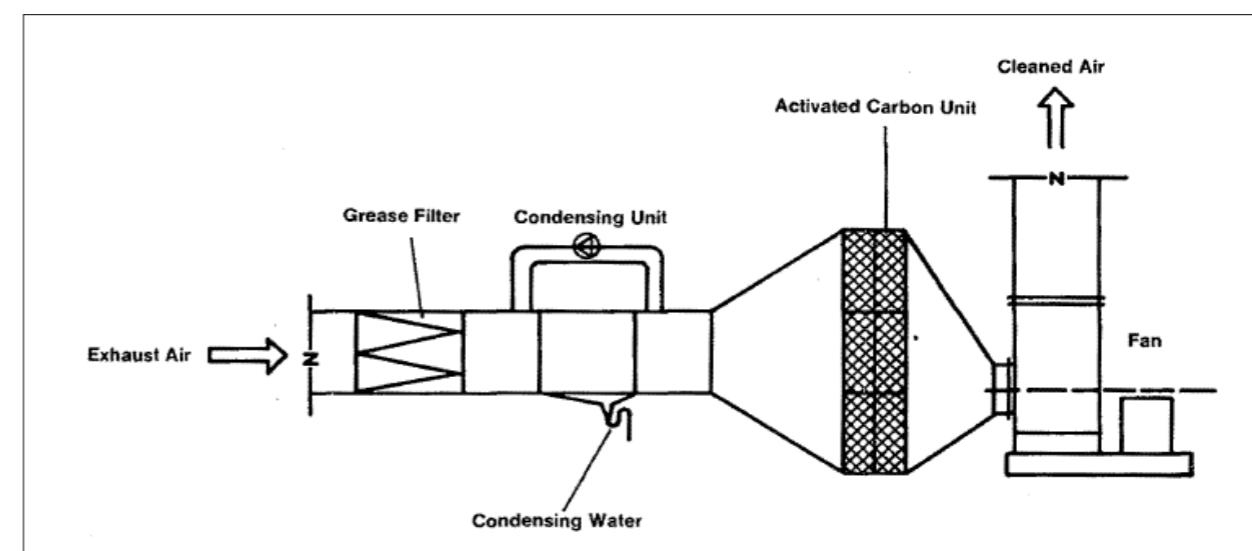

Source: Handbook septage treatment & disposal, US EPA

7.4.3 Types of receiving station

A. Pre-treatment at headworks of STP

These receiving stations need to be present at the start of headworks in a STP. In this case, the receiving station will consist of a dumping station and its main objective will be to safely transfer raw FSS from the hauler trucks to the headworks in a controlled manner. From the receiving station, raw FSS will pass through screening, grit removal in the head works of STP.

The application of this type of receiving station will depend on the location of headworks and availability of land area around it. In this case, slug loading is bound to happen and careful monitoring of STP inlet needs to be done.

Figure 40: Pre-treatment at headworks of STP

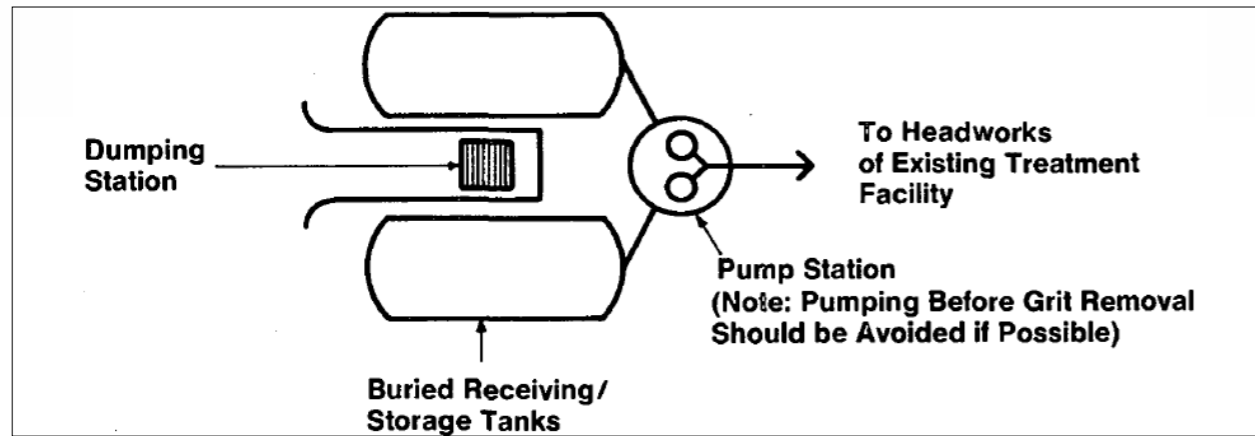

Source: Handbook Septage treatment & disposal, US EPA

B. Pre-treatment before equalisation.

These receiving stations are designed for handling low volume of FSS. In this type of receiving station, the main objectives to be achieved are safe transfer of raw septage, screening, degritting and controlled addition of pre-treated FSS into the STP. An odour control system is optional. However, it is recommended to allocate extra space during its design phase so that it can be added in the future. While designing the screens and grit chamber, one needs to understand how many trucks will be dumping raw FSS simultaneously and accordingly estimate the hydraulic peak flow. To avoid over design of the screening and grit chamber, such receiving stations are recommended for handling small volume of FSS.

Figure 41: Pre-treatment before equalisation.

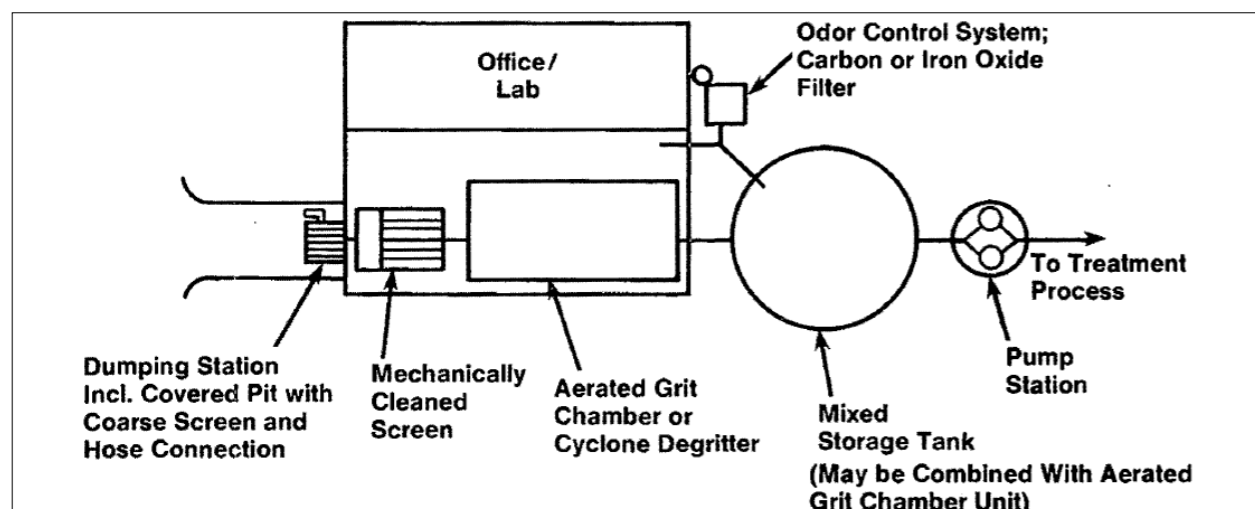

Source: Handbook Septage treatment & disposal, US EPA

C. Pre-treatment after equalisation

This type of receiving station is recommended when large volume of FSS needs to be handled. Cases where large quantities of hauler trucks are going to empty raw FSS, it is logical to store it and then feed it to the screen in a controlled manner. In this way, design of the subsequent treatment units (screens and grit chamber) will be dependent on the maximum design output of the equalisation tank pump. This also reduces the O&M and malfunctioning of the screens and grit chamber. However, it has to be noted that the pump used here should be capable to handle large volume of grit (alternatively sludge pumps can also be used).

Figure 42: Pre-treatment after equalisation.

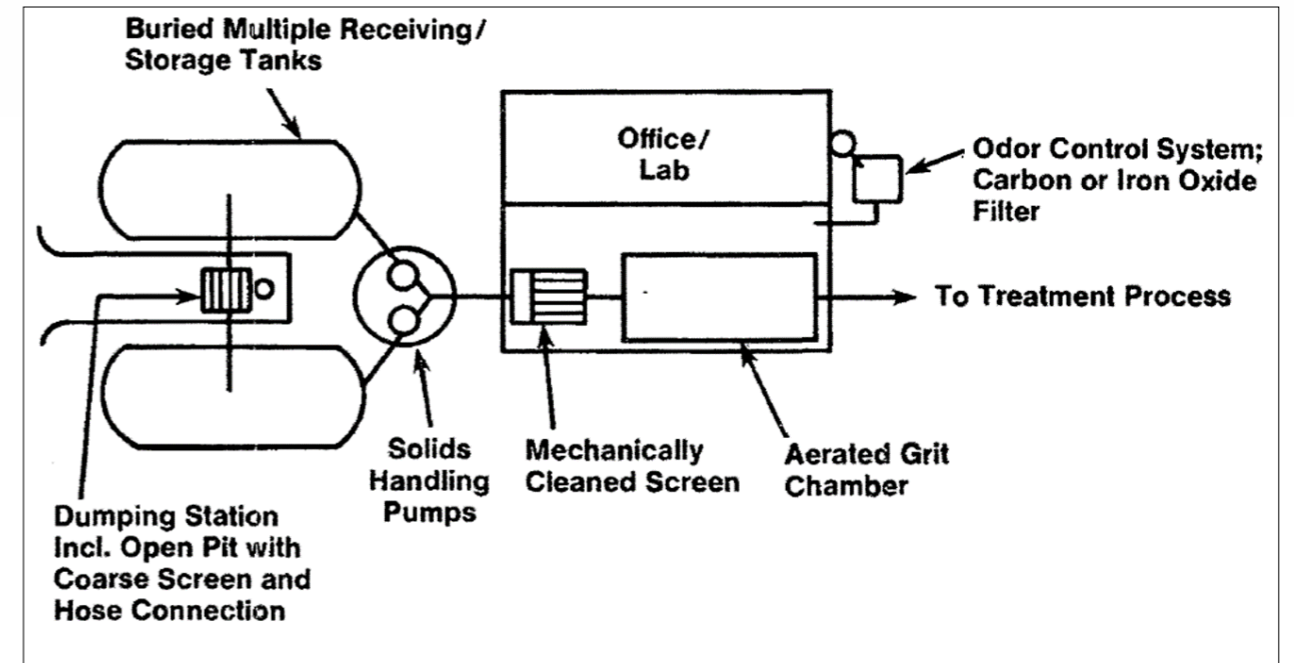

Source- US_EPA, Septage treatment & disposal

7.4.4 Solid-liquid separation

Solid-liquid separation is an important step in sludge handling at faecal sludge treatment facilities or in a co-treatment facility. After solid-liquid separation, the semi-thickened sludge is transferred to a sludge handling facility and liquid will be transferred for liquid treatment. The solid-liquid separation can be carried in following ways:

- Natural system (i.e. settling thickening tank etc.)
- Mechanized system (i.e. by mechanical presses like screw press or belt press etc.).

Stabilised sludge sourced predominantly from septic tanks connected to the households will have good settling/dewatering characteristics. Such sludge is likely to have a large proportion of non-biodegradable COD, which is mostly particulate and settleable. This makes solid-liquid separation a desirable first step for such a type of sludge. Depending on the type of process adopted, a large portion of solid particles and organic pollutants will be removed in this step.

The supernatant will have to be biologically stabilised in the aeration tank with sewage. The thickened sludge may be dewatered and further treated before disposal/reuse.

A. Non-mechanised solid-liquid separation units

Settling thickening tank- These are settling tanks that are designed based on the settling velocities of suspended particles present in the FSS. Difference in the specific gravity aids the settling process. The fat-oil-grease (FOG) has lower specific gravity as compared to water. Hence, FOG can be found floating at the surface of this tank. Solid particles heavier than water settle down and are further compressed as well as thickened by hydrostatic pressure by the water present above. The HRT of a settling thickening tank is in hours, however, sludge retention time (SRT) can be ranging from 10-30 days. A properly designed and well operated settling thickening tank thickens the FSS of solid content in the range of 0.5% to 12%.

In settling thickening tanks, the suspended solid (SS) particles that are heavier than water settle out in the bottom of the tank through gravitational sedimentation. Following types of settling can occur in this tank:

- Discrete, where particles settle independent of each other;
- Flocculant, where particles aggregate and undergo accelerated settling; and
- Hindered, where settling is reduced due to the high concentration of particles.

Figure 43: Schematic diagram of a settling thickening tank

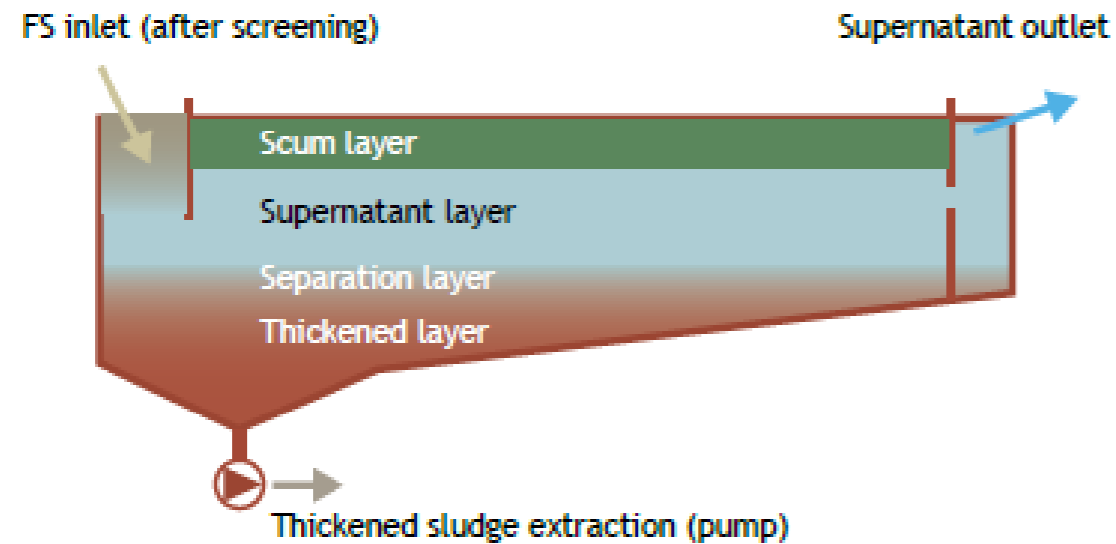

Source: FSM Book, IWA

B. Mechanised solid-liquid separation units

In case of space constraints in an STP, a mechanised dewatering unit is preferred choice for solid-liquid separation. However, before it is subjected to mechanised dewatering, the sludge needs to be conditioned. Conditioning of the sludge is done by addition of coagulant and flocculating the sludge. This produces bigger flocs of sludge, which increases the dewatering efficiency of the mechanised unit.

Screw press- Screw presses separate liquid from solids by forcing sludge through a screw or auger contained within a perforated screen basket. The screw diameter increases with distance along the shaft while the gap between its blades decreases. This reduces the gap between basket, shaft, and flights continuously and sludge is squeezed into a progressively smaller space. This results in an increase in pressure along the press. Pressure probes are used to control and monitor the pressure to ensure treatment performance. The inclined press includes a pneumatic or manually adjusted counter-pressure cone that maintains a constant sludge pressure at the discharge end of the press. Water squeezed out of the sludge is collected in a collector channel present at the bottom and recirculated to liquid treatment units. The dewatered cake drops out at the end of the press for storage, disposal, or further drying on a drying bed or in a thermal dryer. High-pressure water is used periodically inside the press for cleaning.

Figure 44: Schematic diagram of a screw press

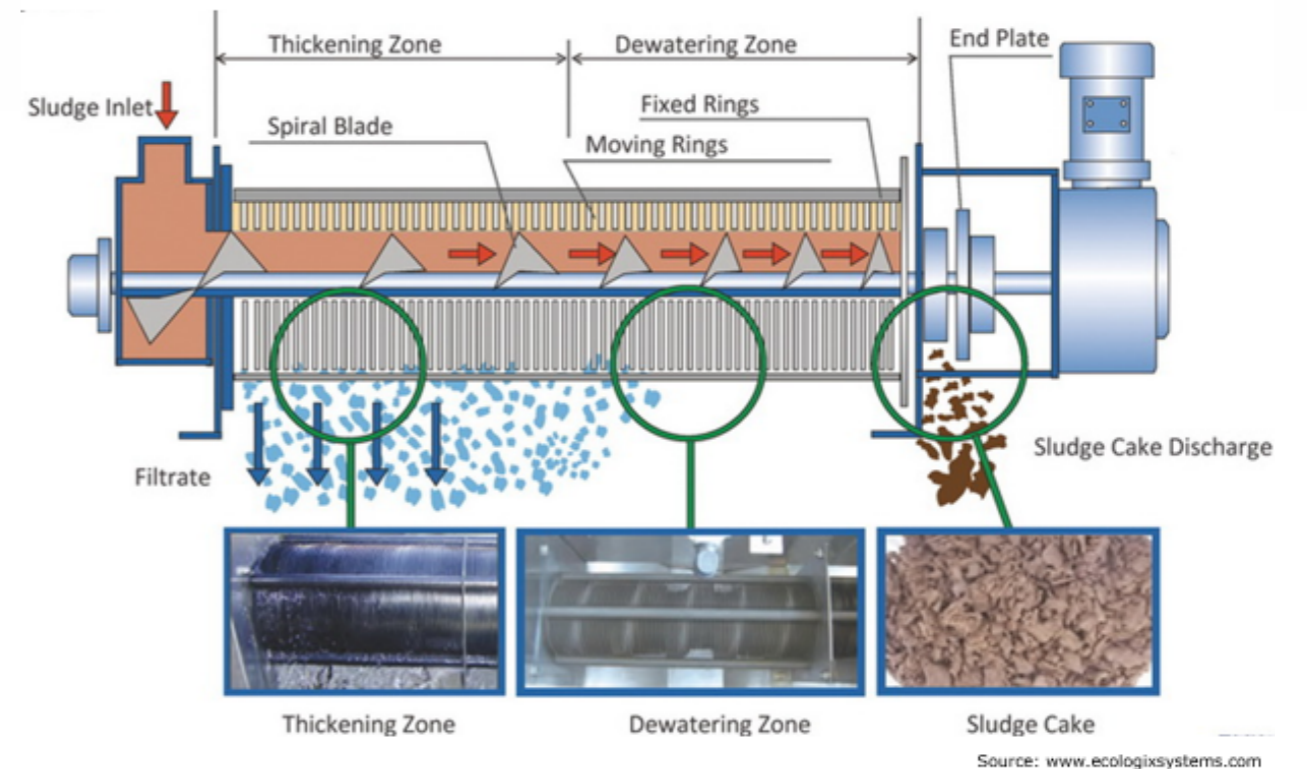

Source: www.ecologixsystems.com

Belt filter press separate liquid from solids, using gravity and applied pressure between fabric belts. The process typically involves four steps: preconditioning, gravity drainage, low-pressure linear compression, and high-pressure roller compression (and shear). After preconditioning, sludge passes through a gravity drainage zone where liquid drains by gravity from the sludge. It is then moved on to a low-pressure zone where two belts come together to squeeze out liquid from the solids, forcing liquid through the fabric belts. In most cases, the sludge is then subjected to higher pressure as it is forced between a series of rollers, which create shearing forces and compression to further dewater the sludge. The dewatered sludge cake is then scraped off the belts for conveyance to the next stage of treatment or disposal. The belts are cleaned with high-pressure wash water after each pass.

Figure 45: Schematic diagram of a belt press

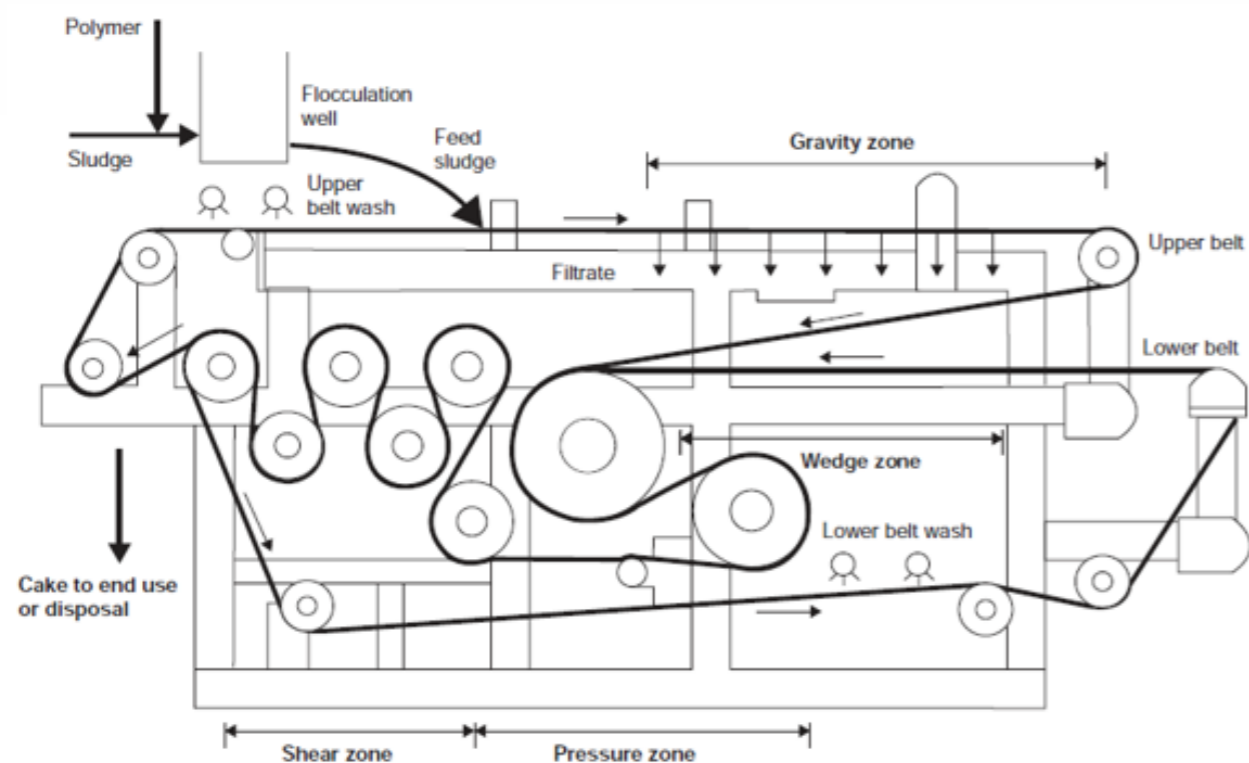

Source: WEF, 2010

7.4.5 Standard operating procedure (SOP) at a septage receiving station

- A. Monitoring at the receiving station before decanting FSS at a treatment facility is critical. A multi-step approach can be used here. A 3-copy receipt system ensures that a paper trail is left with the property owner, desludging operator and the STP operator. This paper trail can be used to assess the indicators for service level benchmarking. The desludging operator should handover a service slip copy to the STP operator. It should be ensured that every property owner signs their respective copy during desludging from their premises. This is necessary to ensure that the FSS is brought from a domestic, public or commercial property and not from any industry.
- B. Preliminary checks such as pH, color, smell, electrical conductivity can help distinguish industrial sludge from domestic sludge. In case of doubt, the sample should be taken and sent for detailed analysis to a certified laboratory. If the samples are found to be having highly deviating characteristics than standard FSS, the particular desludging operator should be fined and questioned. For repeated offence, the license of that particular desludging operator can be revoked.
- C. A log book should be maintained to keep a track of date, time, trip and details of all desludging trucks arriving at the receiving station. This can help to trace back the cause of any issue/ challenge faced at the STP during treatment.
- D. All of the above can also be digitised, which enables the local government to collect substantial data. This data can be further used for analysis and optimising the services. Optimising the services can lead to lowering of the desludging fee and improvement in service provision. This will also lead to increasing the affordability and adoption by households.
- E. In the next step, the treatment units of a receiving station have to be maintained and monitored properly (i.e. regular cleaning of screen, regular maintenance of moving parts in the mechanized systems etc.). The supervisor has to monitor the regular use of appropriate

PPEs by ground staff while working within the treatment plant premises. An inventory log of standby parts or equipment should be maintained as it can help during troubleshooting of the treatment plant.

7.5 Notes for trainer

This session focuses on the importance of having a septage receiving station where FSS can be safely received for treatment. The proper working of each and every component, pre-treatment and its requirement before equalisation was discussed in the session. It is also necessary for the standard operating procedure to be followed at the station to ensure proper operation by the ground staff. Videos related to the topic and case studies might be helpful in understanding.

7.4 Bibliography

Dorai Narayana (2020), Co-treatment of septage & faecal sludge in sewage treatment facilities, International Water Association (IWA).

United States Environmental Protection Agency (US EPA's), Handbook Septage Treatment & Disposal

Marcus Von Sperling (2007), Wastewater characteristics- treatment & disposal, International Water Association (IWA)

Kevin Taylor (2018), Faecal Sludge and Septage Treatment – A guide for low- and middle-income countries

Session

08

Co-treatment in liquid stream at STP

8. Co-treatment in liquid stream at STP

8.1 Session objectives

- A. Understand in detail about the treatment units involved in a liquid treatment stream of an STP.
- B. Learn about the impact of co-treatment and measures to mitigate the impact of co-treatment in the liquid stream of an STP.

8.2 Session plan

Duration - 105 min

Activity	Time	Material/Method
Treatment units and design criteria	15 min	Powerpoint presentation
Feasibility checks	15 min	Powerpoint presentation
Mitigating impact	15 min	Powerpoint presentation
Q & A	15 min	Discussions
Check for primary and secondary treatment units for Activated Sludge Process for co-treatment	45 min	Exercise

8.3 Key facts

- C. Addition of faecal sludge and septage to the liquid treatment stream of an STP will impact the treatment efficiency.
- D. Proper feasibility check and analysis helps to predict the risk of co-treatment.
- E. Solids loading rate and organic loading rate are highly critical rather than hydraulic loading rate in an STP where FSS is added to the liquid stream.
- F. The solids loading rate is important for clarifiers and organic loading rate is important in case of secondary treatment units of STP.
- G. Proper understanding of the ASP process is required for mitigating the risks of co-treatment of faecal sludge and septage in the liquid treatment chain of STP.

8.4 Learning notes

8.4.1 Treatment units and design criteria

A. Primary treatment

Primary clarifier or sedimentation

The primary clarifier is located after screens and grit chambers and reduces the organic load on secondary treatment units. It is used to remove: (i) inorganic suspended solids or grit (if it is not removed in grit chamber described earlier), (ii) organic and residual inorganic solids, free oil and grease and other floating material, and (iii) chemical flocs produced during chemical coagulation and flocculation.

The settleable solids to be removed in primary or secondary clarifiers are mainly organic and flocculent in nature. These are either dispersed or flocculated. Their specific gravity varies from 1.01 to 1.02. The bulk of finely divided organic solids reaching primary clarifiers have low specific gravity. These solids are not flocculated completely but favour flocculation. Flocculation occurs within primary clarifiers due to eddy currents of the fluid. The aggregation becomes complete as the sewage is detained for longer time periods (hydraulic residence time) in these tanks. However, the rate of flocculation rapidly decreases as the detention period is increased beyond a certain value.

Figure 46: Schematic diagram of a primary clarifier

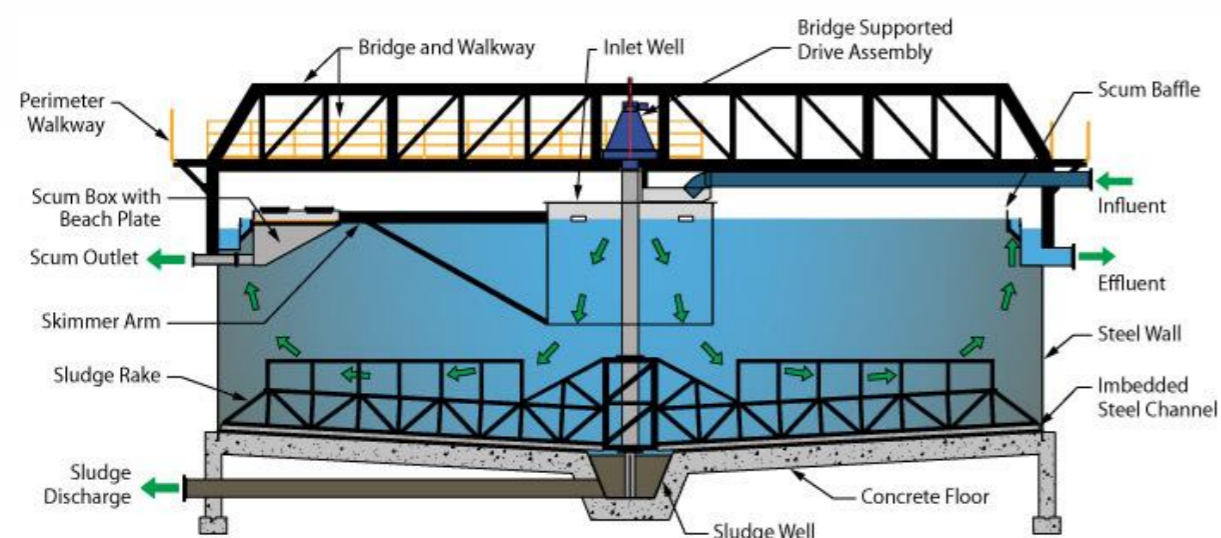

Source: www.sswm.info

Circular tanks are more common than rectangular or square tanks. Up-flow tanks have been used for sewage sedimentation. Diameter of circular tanks vary widely from 3 m to 60 m although the most common range is 12 m to 30 m. Dimensions can be decided by the designer and it should conform to the manufactured sizes of scraper mechanisms. Floors are sloped from the periphery towards the centre at 7.5 to 10%. Inlet to the tank is generally in the centre while the outlet is a peripheral weir that allows radial flow of effluent horizontally towards the periphery of tank. Multiple units are arranged in pairs with feed from a central control chamber.

Several factors such as flow variations, density currents, solids concentration, solids loading, area, detention time and overflow rate influence the design and performance of clarifiers. In the design of some plants, only a few of these factors may have significant effect on performance, while in others all of them may play an important role. In case of a primary clarifier, the design criteria shall consider surface loading rate, solids loading rate, weir overflow rate and side water depth.

Surface loading rate represents the hydraulic loading per unit surface area of the tank in unit time expressed as $m^3/d/m^2$. This must be checked, both, for average flow and peak flow. The solids loading rate is an important decision variable for the design of secondary clarifier which settles the bio-flocculated solids. It is expressed as $kg\ SS/d/m^2$.

Weir loading influences the removal of solids particularly in secondary clarifiers. There is no positive evidence that weir loading has any significant effect on removal of solids in primary clarifiers. However, certain loading rates based on practice are recommended both for primary as well as secondary clarifiers. The loading should however ensure uniform withdrawal over the entire periphery of the tank to avoid short-circuiting or dead pockets. Performance of existing clarifiers for SS removal can be improved by merely increasing their weir length.

Once the surface area is calculated from the overflow rate and solids loading rate, the next step is determining tank depth which influences detention time and vice versa. The depth considered for design is the vertical side water depth. It influences the hydrostatic compression of bottom sludge. Thus, deep tanks will yield sludge with high solid concentration. Tanks with shallow depths will

result in loosely compacted sludge with low solids concentration. This will require huge volumes of wet sludge to be withdrawn for taking out a given weight of sludge solids. In turn, these volumes have a heavy bearing in the required volumes of the sludge handling units and their associated piping and valves etc. Hence, the withdrawal of dense sludge is more beneficial.

Primary clarifiers may be expected to accomplish 30% to 45% removal of BOD, (but shall be taken as maximum of 35% for design) and 60%-70% removal of SS, (but shall be taken as maximum of 60% for design) depending on concentration and characteristics of solids in suspension.

A. Secondary treatment

Activated sludge process reactor

Aerobic suspended growth systems are of two basic types, those which employ sludge recirculation, viz., conventional activated sludge process and its modifications and those which do not have sludge recycle, viz., aerated lagoons. In both cases, sewage containing organic matter is aerated in an aeration basin wherein micro-organisms metabolise the soluble and suspended organic matter. Part of the organic matter is synthesised into new cells and part is oxidized to carbon dioxide and water to derive energy. In activated sludge systems, the sludge generated is a mixture of new cells and dead cells which form the mixed liquor along with the liquid fraction. The mixed liquor flows from aeration tank to clarifier where the solids settle down and are separated from the liquid stream. A part of this activated sludge is recycled to the aeration unit while the remaining is waste or excess sludge.

The suspended solids concentration in aeration tank liquor, also called mixed liquor suspended solids (MLSS), is generally taken as an index of the mass of active micro-organisms in the aeration tank. However, the MLSS represents a combination of micro-organisms, dead cells, and inert organic matter derived from raw wastewater. The nutrients (mainly, nitrogen and phosphorus) should be present in sufficient quantity in the waste or they may be added, as required, for the biochemical reactions to proceed satisfactorily. The recommended ratio of BOD:N:P is 100:5:1. Domestic sewage is generally balanced with respect to these nutrients.

An ASP essentially consists of the following: (i) an aeration tank containing microorganisms in suspension in which the biochemical reactions take place, (ii) an activated sludge recirculation system, (iii) provision for wasting excess sludge and facility to treat it before disposal, (iv) an air supply system to supply oxygen to aeration tank, and (v) a secondary sedimentation tank (secondary clarifiers) to separate and thicken activated sludge.

The loading rate expresses the rate at which the sewage is applied in an aeration tank. A loading parameter that has been developed empirically over the years is the hydraulic retention time. Another empirical loading parameter is volumetric organic loading which is defined as the BOD applied per unit volume of aeration tank per day ($kg\ BOD/m^3/day$).

The activated sludge plant employs a completely mixed flow regime. In a circular or square tank, complete mixing is achieved by mechanical aerators with adequate mixing. The completely mixed flow regime has the capacity to hold a high MLSS level in the aeration tank allowing reduction the tank volume. The plant has increased operational stability during shock loads and increased capacity to treat toxic biodegradable wastes like phenols.

Figure 47: Schematic diagram of activated sludge process

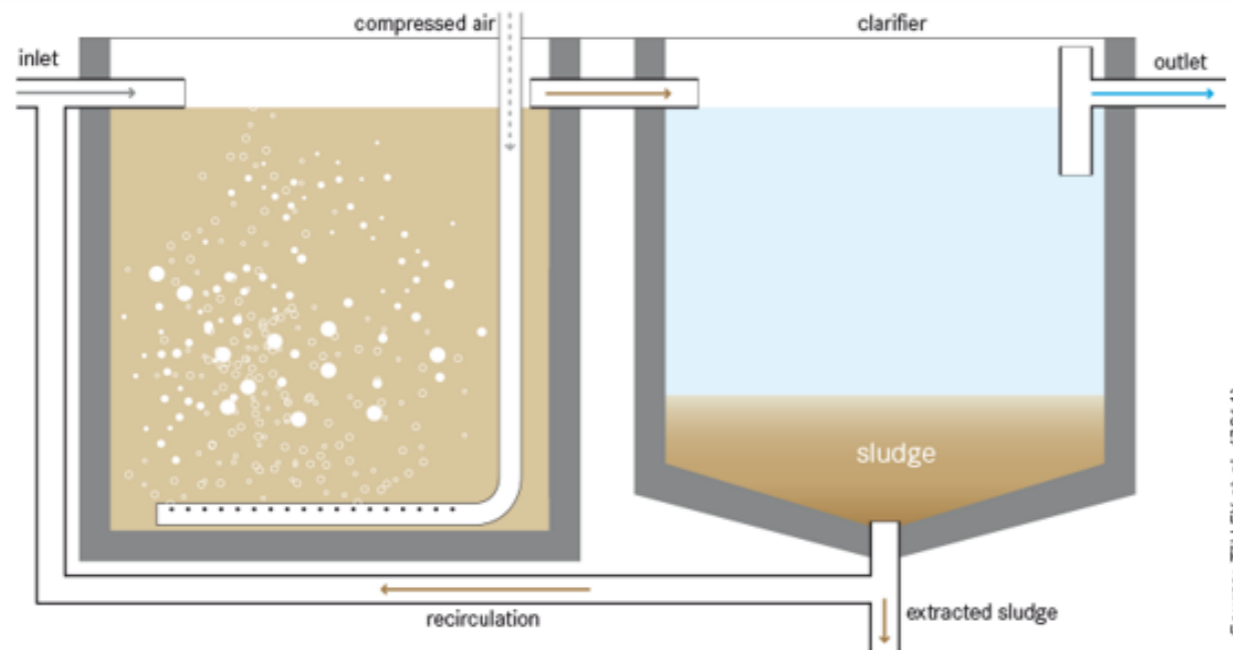

Source: Tilly et al, 2014

The items for consideration in the design of activated sludge plant are aeration tank capacity and dimensions, aeration facilities, secondary sludge settling and recycle and excess sludge wasting.

The volume of the aeration tank is calculated for the selected sludge retention time by assuming a suitable value of MLSS concentration. Alternatively, the tank capacity may be designed for standard food to microorganisms (F/M) ratio and MLSS concentration.

Oxygen is required in the activated sludge process for oxidation of influent organic matter and endogeneous respiration of micro-organisms in the system. Oxygen requirement of 0.8 – 1.0 kgO₂/kg BOD removal for a complete mix system. The extra theoretical oxygen requirement for nitrification is 4.56 kgO₂/kgNH₃-N oxidized to NO₃-N. The amount of oxygen required for a particular process will increase as the F/M value decreases.

The aeration facilities of the activated sludge plant are designed to provide a calculated amount of oxygen against a specific level of dissolved oxygen in the sewage. The equipment used for aeration, apart from supplying the required oxygen demand shall also provide adequate mixing or agitation to allow for all suspended solids to be available for biological activity in the aeration tank. The recommended dissolved oxygen concentration in the aeration tank ranges from 0.5 to 1 mg/l for conventional activated sludge plants and from 1 to 2 mg/l for extended aeration type activated sludge plants and above 2 mg/l when nitrification is required in the ASP.

The aeration equipment also prevents settling of suspended solids in the aeration tank. Installation of aeration equipment shall be based on the air requirements calculated both for summer and winter conditions as well as mixing power. Mixing considerations require that the minimum power input in activated sludge aeration tanks where MLSS is of the order of 4000-5000 mg/l, should not be less than 15-26 W/m³ of tank volume. The power input of aerators derived from oxygenation considerations should be checked to satisfy the mixing requirements and increased where required. For diffused aeration, the air volume for mixing shall be not less than 1.8-2.7 m³/hr/m² of floor area.

Secondary clarifier

Secondary settling is very important in an activated sludge process system. It separates biological sludge from wastewater and gives final treated effluent of desired quality. Additionally, it also helps in maintaining the MLSS in aeration tank by allowing return of adequate sludge. Secondary settling tank or secondary clarifier in an activated sludge process system is particularly sensitive to fluctuations in flow rate. Hence, it is recommended that in an ASP system, the units should be designed for both average overflow rate and peak overflow rates. A high concentration of suspended solids in final effluent indicates that the solids loading rate is also an important design parameter.

Figure 48: Schematic representation of secondary clarifier with main components.

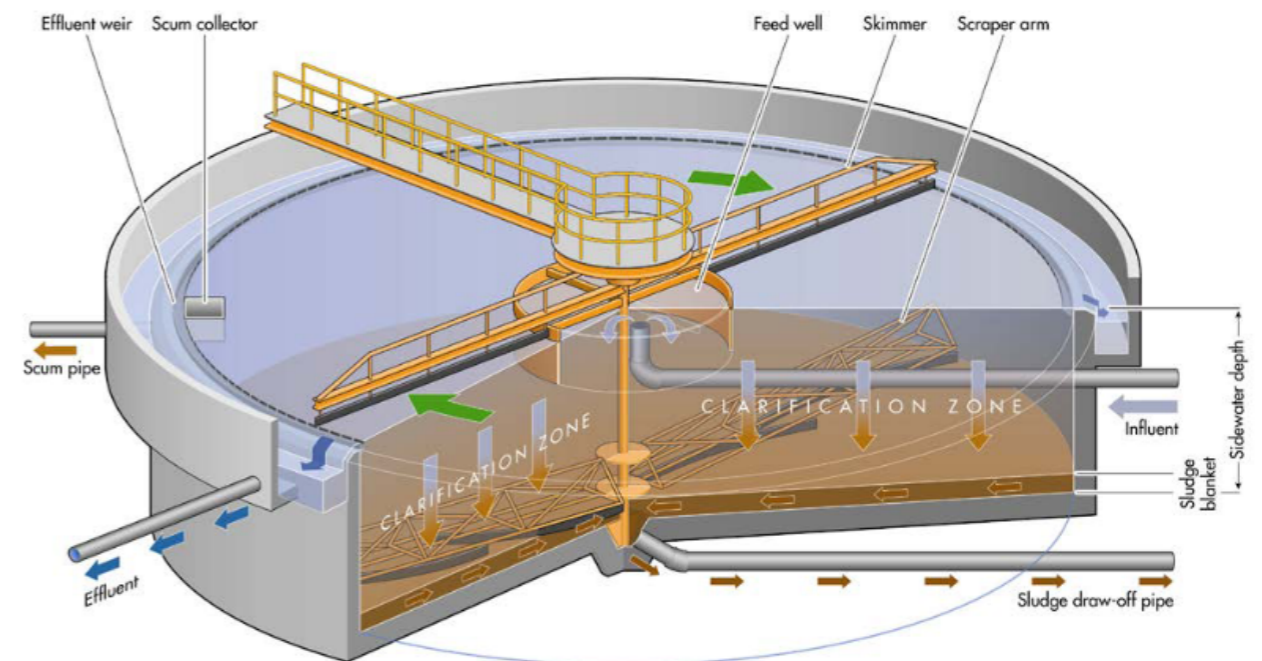

Source: Voutchkov N. (2020)

Settleability of activated sludge is determined by the sludge volume index (SVI) defined as volume occupied in ml by one gram of solids in the mixed liquor after settling for 30 min. SVI is determined experimentally and values in the range of 100 and 150 ml/g indicate good settling of suspended solids. The recirculation ratio computation depends on the sludge concentration in the underflow of a secondary clarifier and this in turn can be attributed to the SVI as mentioned. The SVI is a plant control parameter and cannot be assumed as a design parameter. There has to be flexibility in a fully operational ASP system to vary the recirculation ratio nearer to the higher limit to reach adequate flows. This in turn helps in maintaining flow velocity in pipes throughout the plant despite low inflow of wastewater.

Activated sludge produced from aeration tank has to be wasted to maintain a steady level of MLSS in the system. The excess sludge quantity will increase with increasing F/M and decrease with increasing temperature. For domestic wastewaters, the excess sludge to be wasted will be about 0.35-0.5 kg/kgBOD⁵ removed for the conventional system. Excess sludge may be wasted either from the sludge return line or directly from the aeration tank as mixed liquor. The waste sludge is thickened in a sludge thickening unit and digested directly. In extended aeration plants, the excess sludge is taken to sludge drying beds or mechanical dewatering directly and the sludge filtrate discharged into the effluent stream.

A. Tertiary treatment

Chlorination

Disinfection is the process designed to kill or inactivate most microorganisms in wastewater, including essentially all pathogenic organisms. Contrast this to sterilization, which is the removal and destruction of all living microorganisms, including pathogenic and saprophytic bacteria, vegetative forms and spores.

Chlorine and its various forms are powerful oxidants that will kill or inactivate most pathogenic organisms which prove to be harmful to both human and animal life. Chlorination is the most commonly used disinfection process for wastewater treatment. The chemicals required for chlorine disinfection are easy to obtain, economical, effective and easy to apply.

Chlorine will react with wastewater and combine with many of its components. These components react and combine with chlorine prior to its reaction with pathogens. The demand by inorganic and organic materials is referred to as the chlorine demand. It is the difference between amount of chlorine applied to wastewater and amount of residual chlorine present in wastewater after a given contact time.

Figure 49: Chlorination basin (left) and schematic diagram of chlorine dosing with mixer (right)

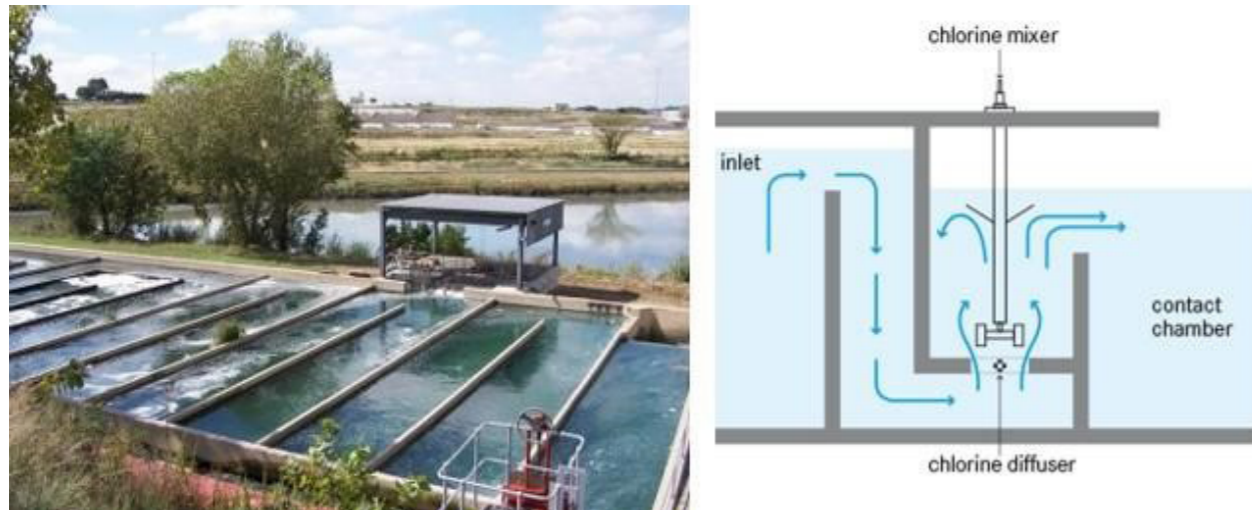

Chlorine dosage may be established from either bench scale laboratory testing, or actual measurement of field results from known plant operation. The results are suitable for establishing base feed rates. However, real time corrections must be made to adjust for field conditions. Since field conditions are not as controlled as laboratory tests, the actual dosage will generally be higher than those established in the laboratory.

The dosage of 10 mg/L is required for secondary treated water. A minimum contact time of 30 minutes should be considered. During this stage, good mixing of chlorine with the water needs to be ensured. A residual chlorine concentration of 1 – 1.5 mg/L is expected. The chlorine demand varies with pH, contact time, temperature, nature and amount of impurities.

8.4.2 Feasibility checks

Primary clarifier

Primary clarifiers are designed for settling using flocculation. Thus, solid loading is not prioritized. However, the solid concentration should be less than 1000 mg/L. As long as the prefeasibility of co-treatment is checked, criteria based on hydraulic loading will not become critical.

ASP reactor

Influent BOD of sewage should be less than design BOD value of the ASP reactor. The actual HRT should be between 4 to 6 hours and should be below the designed HRT.

The aeration need not be checked as long as the HRT is lower than the design value. If actual HRT is less than design HRT or 4 hours, then, aeration capacity needs to be increased.

Secondary clarifier

The secondary clarifier is sensitive to the solids and surface loading rate. Hence, to check the feasibility of co-treatment, the following points should be kept in mind:

- The solids loading rate should be between 70 – 140 kg TSS/d/m²
- The surface loading rate should be between 15 – 35 m³/d/m²

Chlorination

- If all the above checks are satisfied, then there will be no significant change in the chlorine dosage. However, it is recommended to check and adjust the chlorine dosage upon commissioning of co-treatment at the STP.

8.4.3 Mitigating impact

Primary clarifier

Co-treatment will lead to increase in the primary sludge production from primary clarifier. In order to mitigate this, the RPM of scrapper and skimmer blade will need adjustment. Care should be taken that RPM value remains within the desired range in order to hamper the flocculation process of particles.

Removal of primary sludge from the clarifier will have to be increased. This is simply achieved by increasing the operating hours of sludge pumps.

ASP reactor

Impact on ASP reactor can be mitigated by maintaining the F/M ratio and DO of the reactor. To adjust MLSS of a reactor, the return sludge needs to be adjusted. In cases where the adjustment is not possible (due to constraints of the pump etc.), external seeding will be required. Seeding of the reactor can be achieved using active sludge from another ASP reactor or microbial culture commercially available in the market.

DO values of a reactor can be maintained by increasing the operational hours of air blowers. In most of the STPs, since a complete mix reactor is used, this will not be required as the requirement of aeration for mixing will be higher than requirement for removal of BOD.

Secondary clarifier

The production of the secondary sludge will increase and hence sludge wastage might increase after adjusting the return sludge flow. To maintain the TSS removal efficiency, coagulation and flocculation might be required. If this stage already exists, then the dosage of polymer will have to be adjusted.

If the solids loading rate is high or near to the design limit, this might affect the TSS removal efficiency. Thus, to provide higher surface area for the increased solids loading rate, secondary clarifiers can be fitted with lamella plates or tube settler media. This helps to restore the TSS removal efficiency of a clarifier significantly.

Figure 50: Example of tube settler media for retrofitting secondary clarifier



Source: Cooling Tower Filler

The sludge removal will have to be increased. This can be simply done by adjusting the operating hours of sludge pumps.

Chlorination

Chlorine dose needs to be adjusted after monitoring the co-treatment process. In case, if the efficiency of chlorination is not up to the mark, chlorine contact channel can be fitted with static mixers as shown in the picture below. The static mixer is a module which enables proper dispersion of chlorine dose with incoming wastewater. If this does not serve the purpose, then length of the contact channel needs to be increased to increase the contact time.

Figure 51: Schematic representation of static flow mixers

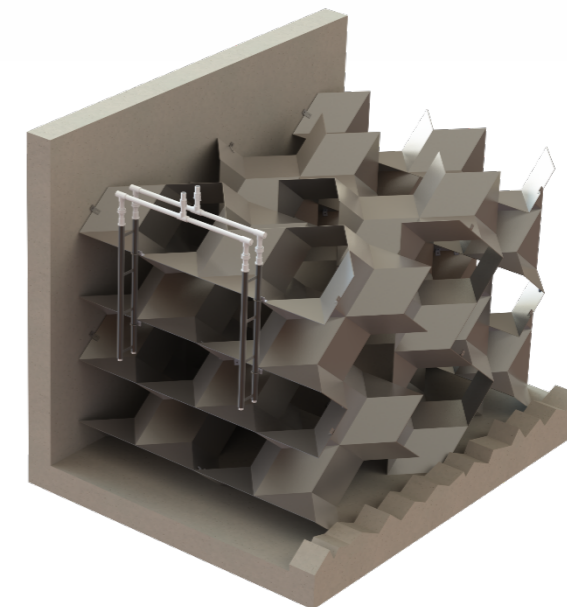

Source: Statiflow

8.5 Notes for trainers

This session contains an exercise for which PART C of this module should be referred first. It is recommended that further knowledge of designing and working of STP is acquired. Solving the exercise prior to the training is advisable, as this will strengthen the understanding of subject matter.

8.6 Bibliography

Dorai Narayana (2019), Co-treatment of septage & faecal sludge in sewage treatment facilities, International Water Association (IWA).

United States Environmental Protection Agency (US EPA's), Handbook Septage Treatment & Disposal

Central Public Health and Environmental Engineering Organization (2013), Manual on Sewerage and Sewage Treatment (Part A).

Tchobanoglous G., Burton F., Stensel H. (2003), Wastewater Engineering – Treatment and Reuse.

Kevin Tayler (2018); Faecal sludge & septage treatment- A guide for low- and middle-income countries

Strande, L.; Ronteltap, M.; Brdjanovic, D. (2014): Faecal Sludge Management (FSM): Systems Approach for Implementation and Operation. London: IWA Publishing

Session

09

Co-treatment in sludge stream at STP

9. Co-treatment in sludge stream at STP

9.1 Session objectives

- A. Understand in detail about the treatment units involved in a sludge treatment stream of an STP.
- B. Learn about the impact of co-treatment and measures to mitigate the impact of co-treatment in the sludge stream of an STP.

9.2 Session plan

Duration- 105 minutes

Activity	Time	Material/Method
Treatment units and design criteria	15 min	Powerpoint presentation
Feasibility checks	15 min	Powerpoint presentation
Mitigating impact	15 min	Powerpoint presentation
Q & A	15 min	Discussions
Check for thickening and digestion treatment units of an ASP system adapted for co-treatment	45 min	Exercise

9.3 Key facts

- C. Addition of faecal sludge and septage to sludge treatment stream of STP will impact only the sludge treatment units.
- D. Proper feasibility check and analysis helps to predict the risk of co-treatment.
- E. Solids and organic loading rates are major constraints while adding faecal sludge and septage in the sludge treatment stream.
- F. Hydraulic loading rate can become a major constraint while adding faecal sludge and septage in the liquid treatment stream.
- G. The most critical component is anaerobic digester and detailed understanding about its operation is required for co-treatment of faecal sludge and septage with sewage at STP.

9.4 Learning notes

9.4.1 Treatment units and design criteria

A. Primary treatment unit

Gravity thickener

Gravity thickeners have a similar shape and function to that of a sedimentation tank or a clarifier. Usually they are circular in shape, centrally fed, and have a hopper shaped bottom to ease sludge removal. Supernatant is collected from the upper half of this unit and recirculated to the headworks of STP for treatment.

Figure 52: Gravity thickener

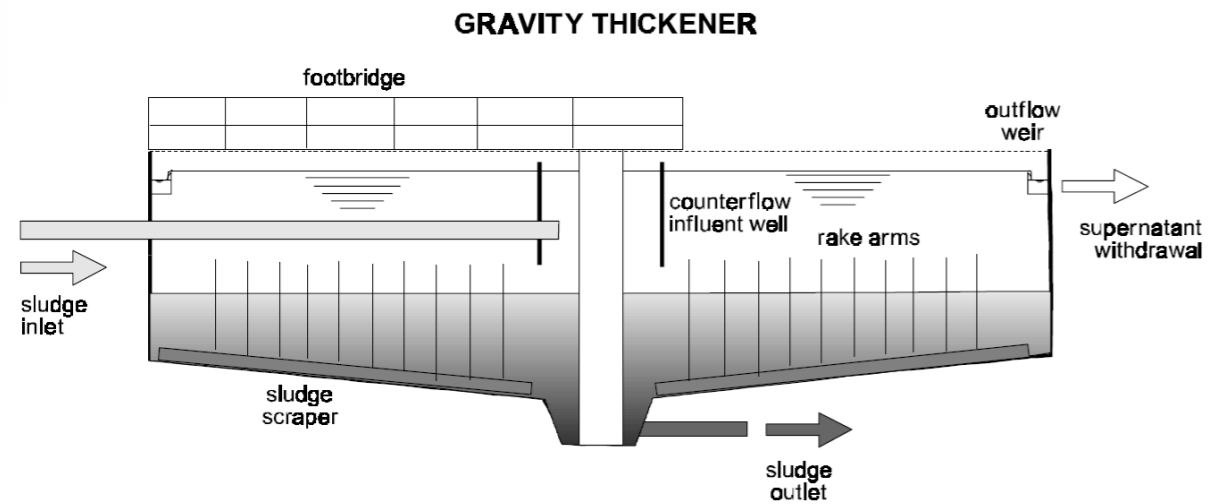

Figure 47: Gravity thickener (Source- Wastewater characteristics, treatment & disposal; IWA)

In case of mixed sludge, a solid loading rate between 25 – 80 kg TS/d/m² area of the thickener is recommended. Solids loading rate is important for maintaining the solids removal efficiency in a gravity thickener. Hydraulic loading is important in controlling excessive detention times, which could lead to the release of foul odours. Hydraulic loading rates ranging from 20-30 m³/d/m² are recommended. To achieve these values for hydraulic loading, the final effluent of STP is recirculated to the thickener. The side water height is kept at least 3.0 m and the maximum hydraulic detention time is 24 hours.

B. Secondary treatment unit

Anaerobic digester

Anaerobic digestion processes are of different types such as: (a) psychrophilic, (b) mesophilic, and (c) thermophilic. Mesophilic anaerobic digestion is appropriate for Indian context as it demands operating temperature of 20 °C – 40 °C with SRT of 20-30 days.

Anaerobic digestion takes place in four stages and a state of balance needs to be maintained in this process. The four stages of anaerobic digestion are: (1) hydrolysis of slowly biodegradable contents such as fats, cellulose and proteins, (2) acidogenesis, (3) acetogenesis, and (4) methanogenesis. The second and third stage results in generation of organic acids which lowers the pH of the reactor. However, the fourth stage is sensitive to pH and is a slow step. Hence, if there is an increase in production of acids, the pH will drop out of the desired range and souring of digester takes place.

On the other hand, if organic loading is not maintained properly, then the microorganisms scavenge each other killing the biological activity of digester. In both cases, recommissioning of anaerobic digester may be needed.

Following are some of the main requisites for sludge digestion:

- The incoming sludge should be free from large concentrations of fibers, plastics and other inert materials. These materials can lead to breakage of pipes or damage the pump rotors. Also, these materials create an unfavourable condition for the development of sludge blanket in case of an upflow anaerobic sludge blanket (UASB) digester unit. Furthermore, the inert material can lead to a decrease in the net volume available for digestion and thereby hamper the digestion process.
- The solids concentration should be between 4% – 8%. Higher concentrations can also be used as long as the feeding and mixing mechanism can handle these concentrations.
- The sludge should not contain digestion inhibiting substances such as hydrocarbons, organochlorinated compounds, non-biodegradable anionic detergents, oxidizing agents and inorganic cations. The source of wastewater can provide a fairly approximate idea whether such inhibitory compounds are present in the waste stream. Analysis of these compounds in the laboratory is a complex and financially expensive activity.
- The sludge should not contain higher concentration of metals. These metals can inhibit the anaerobic digestion by reacting with the enzymes forming insoluble complex compounds.

Figure 53: Schematic diagram of a high rate anaerobic digester

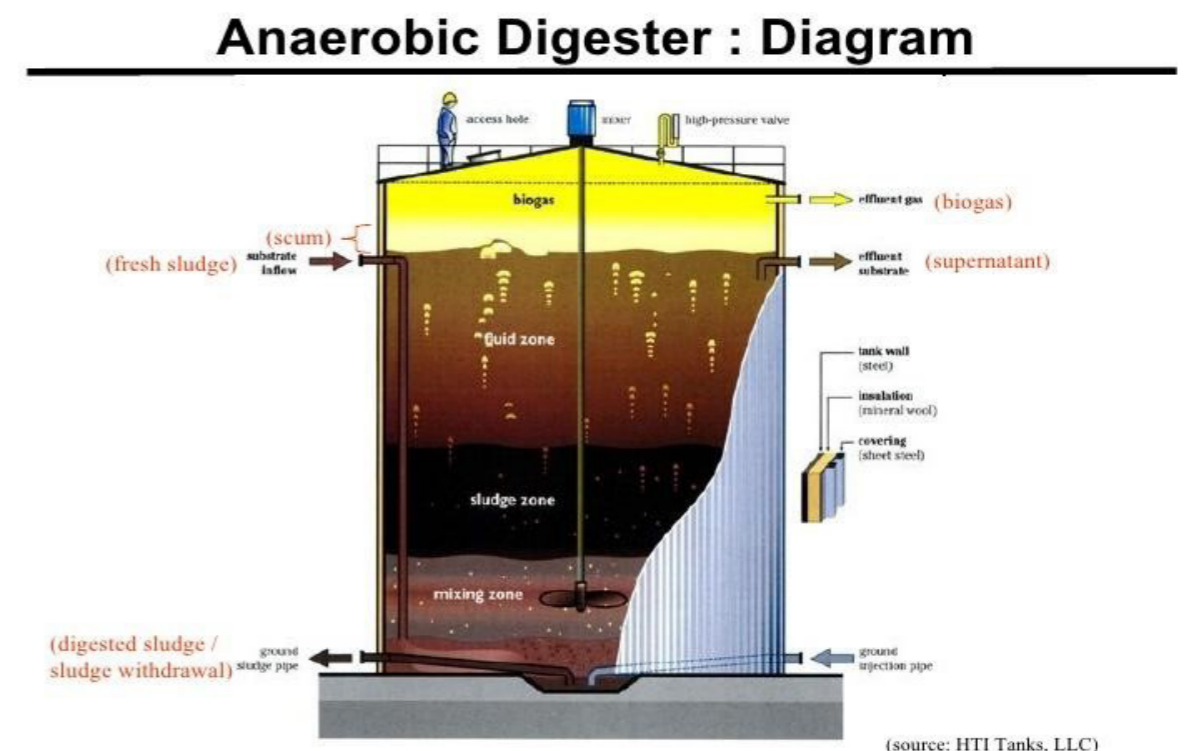

Source: HTI Tanks, LLC

The detention time of the sludge inside the digester is a key design criteria and should be between 18 – 25 days. The organic loading rate is another critical criterion and should be maintained between 0.8 – 1.6 kg VSS/d/m³. The solids loading rate should be maintained between 1.0 – 2.0 kg SS/d/m³.

C. Tertiary treatment unit

Mechanised dewatering

Centrifugation is a solid-liquid separation operation guided by the action of centrifugal force. In the first stage, sludge particles settle at a velocity much higher than the velocity due to gravity. In the second stage, compaction occurs that causes the sludge to lose some portion of capillary water. The cake is removed from the process after this last dewatering stage.

Centrifuges are equipment that may be used indistinctly for sludge thickening and dewatering. It follows the same principle of operation and is found to give good results when they are provided in series. When a series arrangement is made, the thickening and dewatering operations are performed by the first and second centrifuges, respectively. The main types of centrifuges used for sludge dewatering are vertical and horizontal-shaft centrifuges. The difference between these two types are the method of feeding the sludge, intensity of centrifugal force, and manner in which the solid cake and liquid are collected from the centrifuge. Currently, the majority of treatment plants that dewater sludge by centrifugation use horizontal-shaft centrifuges. The semi-continuous feeding of the sludge and relatively lower solid concentration in the cake produced by the vertical-shaft centrifuges are some of the reasons for this preference.

Figure 54: Centrifuge dewatering equipment

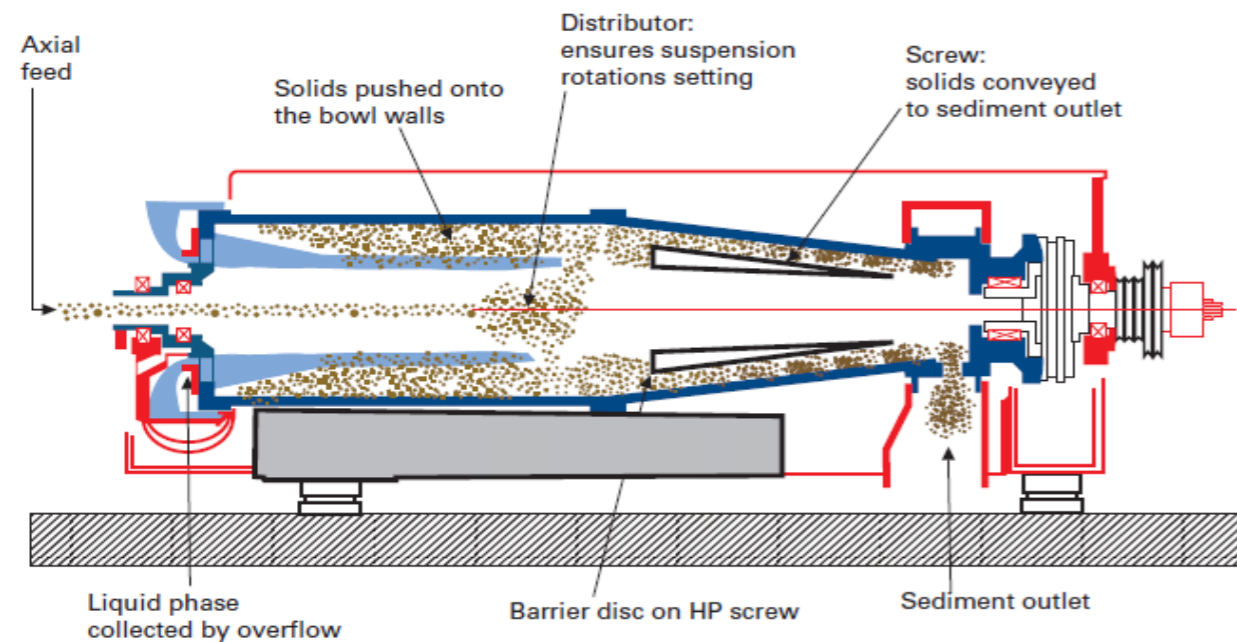

Source- Seuz water handbook

These centrifuges are designed as per the proprietary design criteria set by equipment manufacturers. These manufacturers need to be provided with all the required details such as solids loading rate and solid content of the sludge. Appropriate model of the centrifuge is then recommended by the manufacturer. Solid cake produced by the centrifuge is mainly dependent on incoming sludge characteristics. In case of anaerobic sludge, the solids concentration of up to 40% can be reached.

9.4.2 Feasibility checks

Addition of faecal sludge and septage at an STP is possible at multiple points. The figure below illustrates all the points feasible for addition of faecal sludge and septage. However, it is clear that addition of sludge in the liquid stream will affect the subsequent treatment units in liquid as well as solids stream.

Figure 55: Points of septage addition in a typical STP

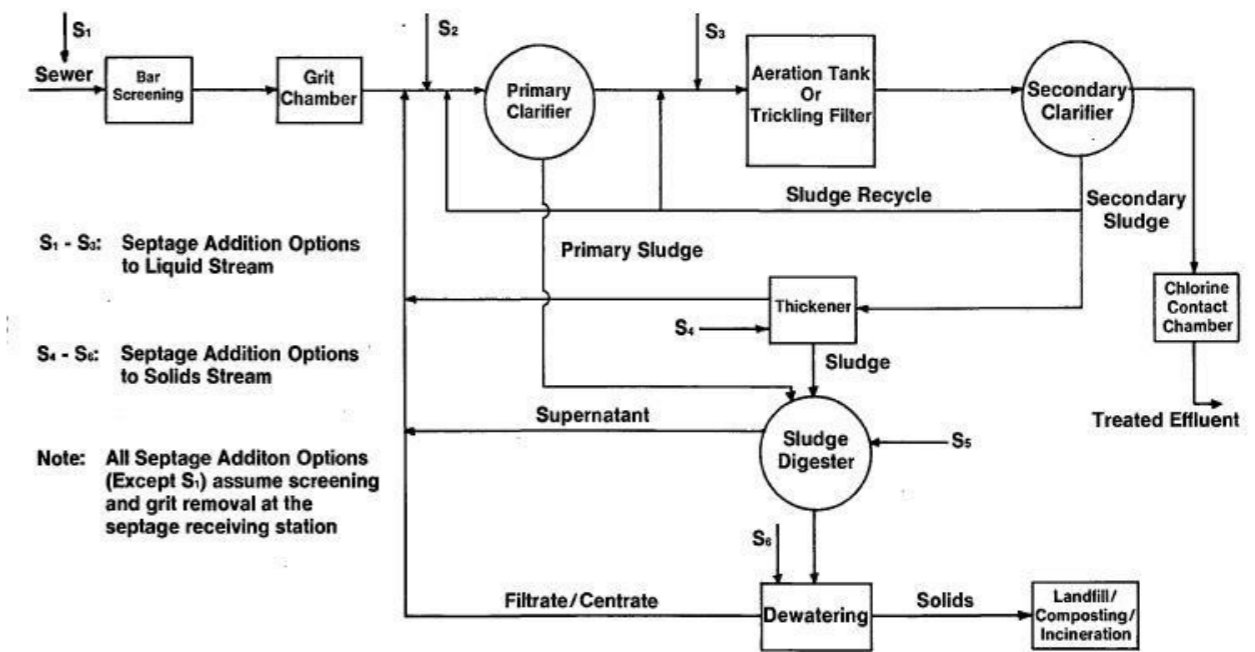

Source: Handbook Septage treatment & disposal, US EPA

Gravity thickener

In case of a gravity thickener, the feasibility check needs to be done for solids loading rate per unit area of the thickener. This number should be between 25 – 80 kg TS/d/m². The surface loading rate should be between 20 – 30 m³/d/m². The HRT should not be more than 24 hours. For maintaining the solids loading and surface loading rate, the digester effluent or treated effluent is recycled into the thickener.

Anaerobic digester

Volumetric load of solids on the digester should be checked. It should be between 1.0 – 2.0 kg SS/d/m³ and the organic volumetric loading rate should be between 0.8 – 1.6 kg VSS/d/m³. The detention time also needs to be checked and should be ideally more than 18 days.

Mechanised dewatering

There is a possibility that there is an increase in volume of digested sludge from the anaerobic digester. In such cases, the operation time of centrifuge will have to be increased. There will also be an increase in the solids concentration and hence, dosage of polymer needs to be adjusted for conditioning of the sludge.

9.4.3 Mitigating impact

Gravity thickener

The mitigation measures of gravity thickener are very similar to that of the primary clarifier. As the volume of thickened sludge will increase, its removal needs to be done frequently. This will cause an increase in operation hours of sludge pumps. The STP operator will have to adjust the return flow of effluent from digester and treated water to maintain the solids loading rate and hydraulic loading rate of the thickener. This is essential to maintain the TSS removal efficiency close to its design efficiency.

Anaerobic digester

The symptoms of instability of the anaerobic digester and its probable causes are mentioned in the table below. The table also provides mitigation measures for each symptom.

Table 13: Factors leading to instability of the anaerobic digester and mitigation measures

Factors leading to instability			Symptoms	Recommended measures
Hydraulic shock	Organic shock	Toxic load		
Excessive sludge production	Increase in sludge influent	Excessive concentration of heavy metals	Increase in volatile acids concentration	Adjust alkalinity using alkaline solution (Lime)
Very dilute sludge in feeding	Increase in solids concentration	Excessive detergent load	Alkalinity reduction, pH reduction	Lower volatile acids, alkalinity ratio to < 0.5
Digester silting	Change in sludge characteristics	Chlorinated organic compounds in sludge	Increase in volatile acids/alkalinity ratio	Regulate feeding routine
Excessive foam	Too fast digester start-up	Addition of oxygen	Reduction of gas production	Raise sludge concentration & restrict industrial influent
Methanogenic organisms wash out	Irregular feeding	Excessive sulphides	Increase in CO ₂ concentration in biogas	Clean the digester & initiate start up protocol

Source: Andreoli C. et. al., (2007)

Mechanized Dewatering

The following table gives a list of operational problems alongwith the corresponding consequence arising in general with mechanised dewatering dewatering and its probable solution.

Table 14 : Operational problems and mitigation measures for mechanised dewatering

Operational problem	Consequence	Solution
Inadequate material blades	Excessive abrasion	Replace with more resistant material
Rigid feeding pipes	Pipe cracks and joints leaks	Replace with flexible pipes
Grit in the sludge	Excessive abrasion of the equipment	Either review operation or install grit chamber
Higher solids loading	Inadequate dewatering performance	Adjust the polyelectrolyte feed
Excessive vibrations	Destabilization of electric and mechanical parts	Install adequate shock absorbers

Source: Andreoli C. et. al., (2007)

9.5 Notes for trainer

This session contains an exercise which has been explained in the PART C of this module. It is advisable that the exercise be solved before this session in order to understand the fundamentals of co-treatment of faecal sludge and septage by addition in sewage sludge stream. It is recommended to read the literature give below for deeper understanding of the subject matter.

9.6 Bibliography

Dorai Narayana (2019), Co-treatment of septage & faecal sludge in sewage treatment facilities, International Water Association (IWA).

Central Public Health and Environmental Engineering Organization (2013), Manual on Sewerage and Sewage Treatment (Part A).

Tchobanoglous G., Burton F., Stensel H. (2003), Wastewater Engineering – Treatment and Reuse.

Andreoli C., Sperling M. and Fernandes F. (2007), Sludge Treatment and Disposal, International Water Association (IWA)

Session

10

Disinfection of sludge

10. Disinfection of sludge

10.1 Session objectives

- A. Understand the different treatment technologies available for disinfection of sludge and reuse of biosolids.
- B. Learn about the co-composting approach, thermal drying of sludge and thermal treatment of biosolids.

10.2 Session plan

Duration- 90 minutes

Activity	Time	Material/Method
Treatment objectives	5 min	Powerpoint presentation
Co-composting	10 min	Powerpoint presentation
Thermal drying	15 min	Powerpoint presentation
Thermal treatment of bio solids	15 min	Powerpoint presentation
Q & A	30 min	Discussion with videos
Exercise	15 min	Exercise

10.3 Key facts

- C. Solar drying requires more area as compared to thermal drying, however the energy required is significantly less.
- D. Thermal drying is more controllable as compared to solar drying, however it is more expensive for implementation and O&M.
- E. Thermal treatment of sludge consists of incineration and pyrolysis of dewatered-dried sludge.
- F. The sludge needs to be dried in order to increase the solid content to more than 60% for incineration. Higher the solid content, better is the combustion process.
- G. This equipment does have high CAPEX and OPEX, however provides significant bio-safety and reduction in the volume of the end product.

10.4 Learning notes

10.4.1 Treatment objectives

Septage disinfection or the destruction or inactivation of pathogenic organisms in faecal sludge and septage is carried out principally to minimize public health risks. Destruction is the physical disruption or disintegration of a pathogenic organism, while inactivation is the removal of a pathogen's ability to infect.

The treatment objectives are: a) to reduce or eliminate the pathogens, microorganisms and dewater the solids, b) to make it safe for handling of biosolids, and c) the safe end-use of dewatered solids or biosolids in agriculture, horticulture or other applications.

10.4.2 Co-composting

Co-composting can be performed on the dewatered sludge. Sludge is rich in nitrogen and if mixed with organic solid waste to achieve a C:N ratio of 30 then aerobic composting can be achieved. Thermophilic condition is required for pathogen inactivation and hence care needs to be taken to achieve optimum temperature and maintain oxygen concentration between 40% - 60%. The advantage of co-composting is the simultaneous occurrence of drying and pathogen inactivation processes. This generates an end product having a decent safety standard as well as higher

monetary value in the market. Limiting factors to practice co-composting can be technical and managerial skills along with the area required to manage the piles.

There are two types of co-composting designs: open and in-vessel. In open composting, the mixed material (sludge and solid waste) is piled into long heaps called windrows and left to decompose. Windrow piles are periodically turned to provide oxygen and ensure that all parts of the pile are subjected to the same heat treatment. In-vessel composting requires controlled moisture and air supply, as well as mechanical mixing. Therefore, it is not generally appropriate for decentralised facilities.

Operation and maintenance

A well-trained staff is necessary for the operation and maintenance of any treatment facility. Maintenance staff must carefully monitor the quality of input raw material. It is also important to keep track of the inflows, outflows, turning schedules, and maturing times to ensure production of a high-quality end-product. Forced aeration systems must be carefully controlled and monitored while operating for the aeration of windrows.

Turning must be periodically done with either a front-end loader or by hand. Robust grinders for shredding large pieces of solid waste (i.e. small branches and coconut shells) and pile turners help to optimize the process, reduce manual labour, and ensure a more homogenous end product.

Figure 56: Schematic diagram of co-composting process

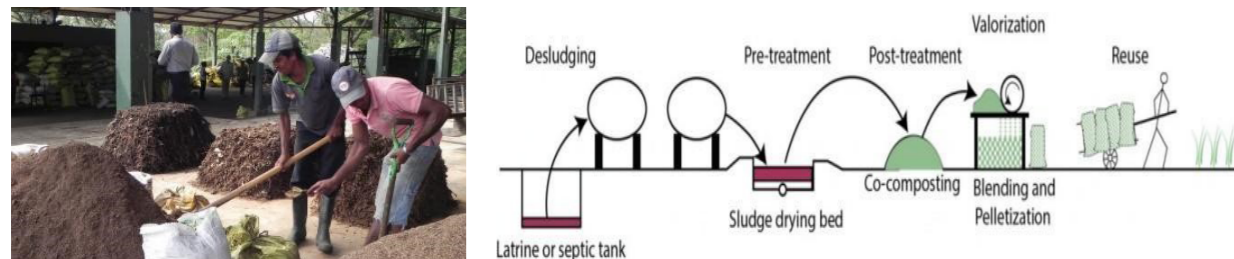

Source- www.wateratleeds.com

10.4.3 Solar drying house

The solar sludge drying house is a conventional method used for drying of sludge. Forced ventilation coupled with tilling equipment is used to drive out the moisture at a higher rate from the sludge. The material used for preparing the covering (shed) is such that it allows entry of solar radiation inside and get trapped. The solar radiation heats up the dry air which absorbs the moisture from the sludge. The moisture laden air is then forced out of the drying house through a ventilation system.

Figure 57: Typical schematic of solar drying house for sludge treatment

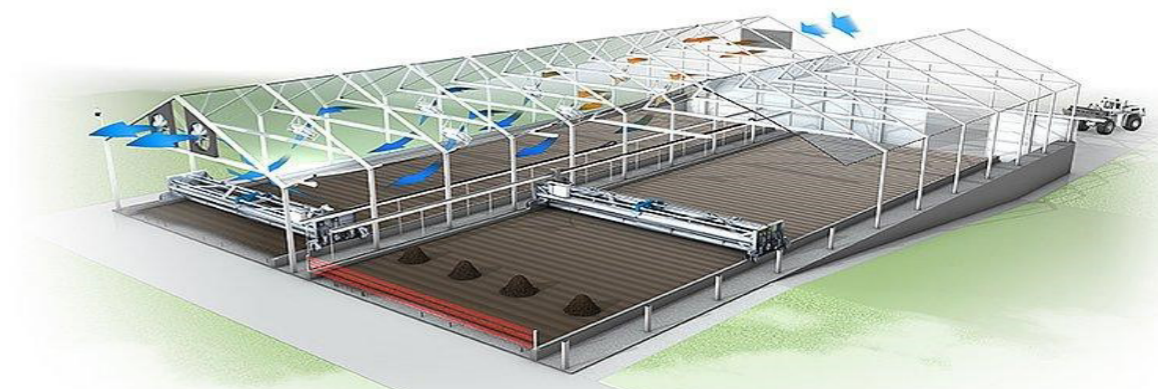

Source: www.huber.de

The performance of solar sludge drying is dependent on solar radiation, air temperature, relative humidity of air, and depth of sludge. Ventilation flux controls the relative humidity and accelerates the evaporation process of moisture from sludge. The initial water content and depth of sludge also affects the performance of drying. To regulate the depth of sludge and to expose maximum area of the sludge, tilling equipment is used, which tosses and turns the sludge while maintaining a constant height and exposes it to the relatively dry air.

The drying cycle time of the sludge depends on the initial solid content, evaporation rate which is dependent on solar radiation, air temperature, ventilation rate, and sludge depth. The sludge depth can vary from 150 – 400 mm. However, it is recommended to have tilling mechanisms for higher depths such as 250 mm. A ventilation rate of 150 m³ per square meter area of solar sludge drying house is recommended. However, it is completely dependent on the site conditions and should be adjusted accordingly.

Since mechanical equipment is used for forced ventilation and tilling, a continuous and reliable source of electricity is required for operating the solar drying house. There should be multiple beds especially in places which have high humidity or significant variation in temperature on an annual basis. As a maintenance measure, the covering of solar drying house should be cleaned on a regular basis.

10.4.4 Thermal drying

There are two types of thermal drying- direct thermal dryer and indirect thermal dryer. Direct thermal dryer refers to the process where hot air is used to drive away the moisture. On the other hand, indirect thermal dryer refers to the process where heat is transferred using a medium such as oil, sand etc.

Generally, for a thermal dryer, the initial solid content should be approximately 60%. This is required so that the sludge moves through the dryer without sticking to its walls. The dried sludge in the end has a solid content of 90-95%. Thermal dryers have high energy requirements, since

a tremendous amount of energy is required to heat the water and thereby vaporise it. However, thermal dryer require significantly less area for processing the sludge. In optimised operation, efficiency of the dryer is more than 80%. Health and safety considerations such as production of dust should be taken into account. Operators need to be trained properly and persons with skills and expertise are required for operating such equipment.

A. Direct thermal dryers

Rotary dryer

The simplest form of dryer is the direct rotary dryer. This consists of a cylindrical steel shell that rotates on bearings and which is mounted horizontally, with a slight slope down from the feed end to the discharge end. The feed sludge is mixed with hot gases produced in a furnace and is fed through the dryer.

As it passes through the dryer, flights (fin-like attachments to the wall of the cylinder) pick up and drop the sludge, causing it to cascade through the gas stream. Moisture in the sludge evaporates, leaving a much dryer material at the discharge end of the dryer. The dried sludge is separated from the warm exhaust gas, part of which is recycled to the dryer while the remainder is treated to remove pollutants and is then vented to the atmosphere.

Figure 58: Schematic diagram of a rotary drum dryer (Source: www.benenv.com)

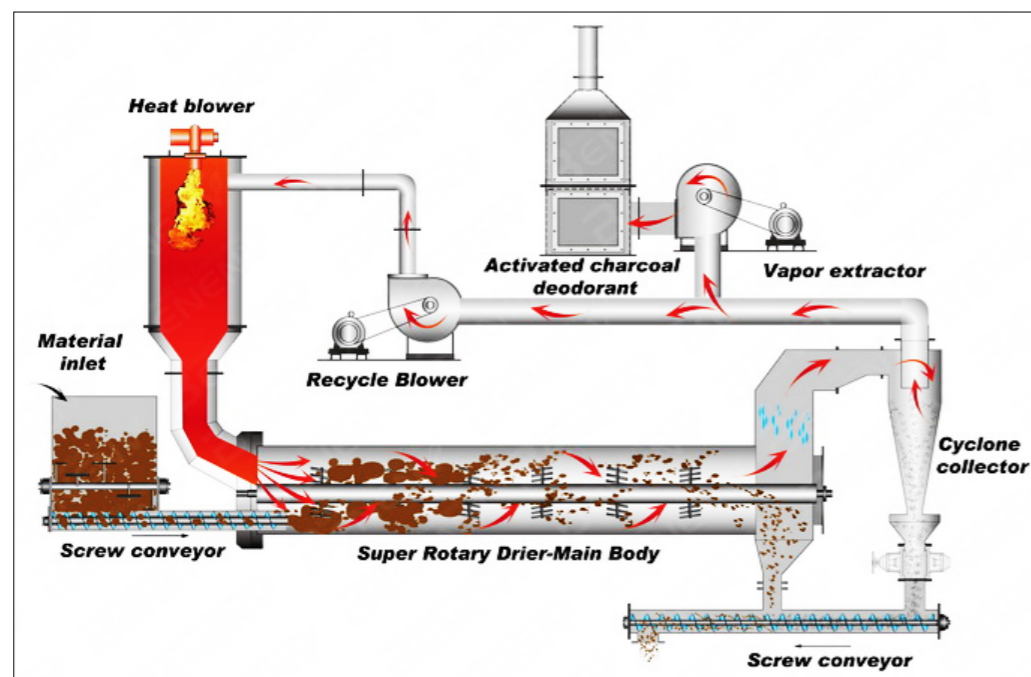

Source: www.benenv.com

Belt dryers

Belt dryers operate at lower temperatures than the rotary drum dryers. The heat from the furnace is transferred to a thermal fluid, which heats the air in the dryer. Alternatively, electrical heating coils are also used to heat the air in the dryer. The dewatered cake that is to be dried is distributed onto a slow-moving belt, which exposes a high surface area to the hot air.

Figure 59: Schematic diagram of a belt dryer

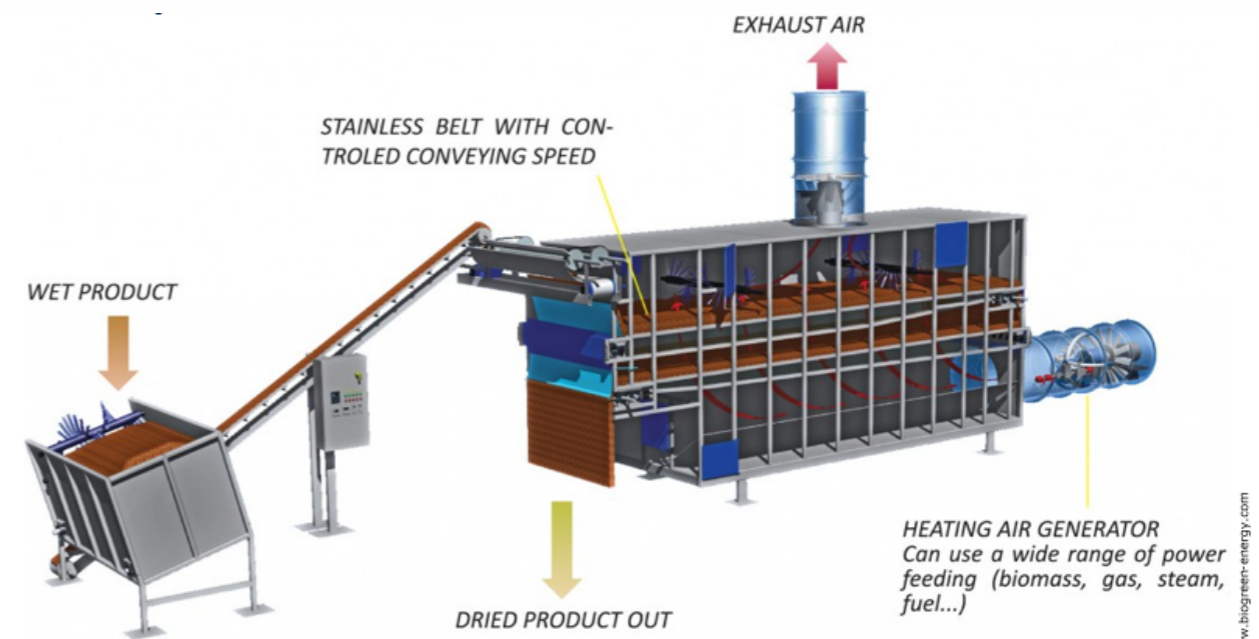

Source: biogreen-energy.com

B. Indirect thermal dryers

Paddle dryers

Paddle dryer has paddle wings which are hollow from inside so that steam can be circulated from it. The paddle system is also encompassed into a jacket which is fed by steam. When raw material is introduced into the paddle dryer, heat transfer occurs from the paddles to the sludge material. The sludge moves in the forward direction and gets churned as it moves ahead. Dried solids comes out from the other end of the dryer. Dry air is introduced in the jacket to drive away the moisture laden air out of the dryer.

Figure 60: Schematic diagram of a paddle dryer

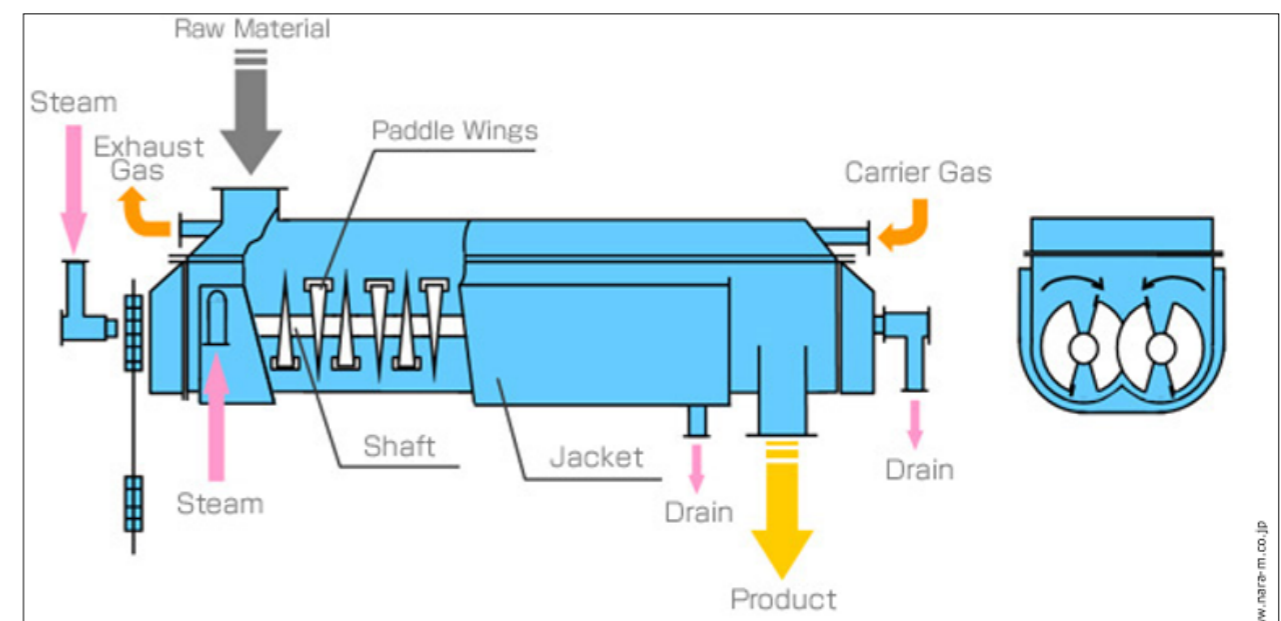

Source: www.nara-m.co.jp

Fluidised bed dryer

The fluidised beds have been used for drying in Europe and USA since the 1940s to create pellets of sludge. In such a dryer, the medium (sand) is heated and kept in the fluidised state by introducing hot air in the reactor. The wet sludge is then introduced into the reactor and flash drying takes place. Thereafter, the heated solids are cooled using cool air before they are taken out of the reactor. Here, cyclone de-gritters are used to remove dust from the hot and cold air coming out of the reactor. Fluidised bed reactor is quite complex to operate and its energy requirement is high as well.

Figure 61: Schematic of a fluidised bed dryer

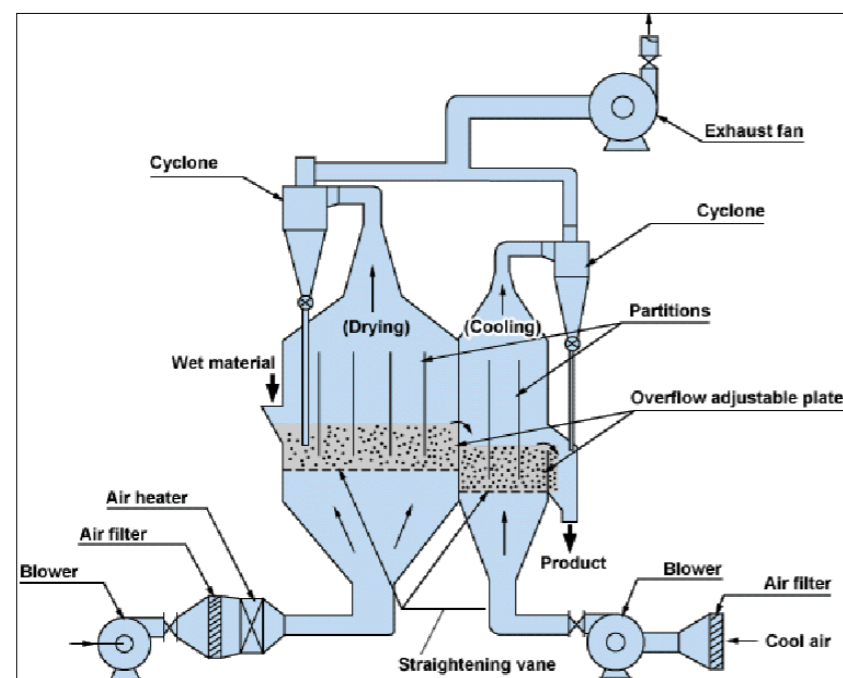

Source: Kurimoto, 1997

10.4.5 Thermal treatment of bio-solids

Incineration refers to complete combustion of organic matter at high temperatures. The resulting ash gives a sludge volume 10% lower than its initial volume. Thus, incineration can be seen as a disposal mechanism for reducing the volume of end product to be disposed or to generate heat or electricity which can be used for various processes. The fly ash which is created as an end product can be used as raw material for making bricks.

Incineration of sludge can be achieved in two ways – mono-incineration and co-combustion. As the name suggests, mono-incineration refers to incinerating the sludge individually in different types of furnace. Co-combustion on the other hand refers to incinerating the sludge with some other material such as municipal solid waste, coal in power plants etc.

Energy content in the faecal sludge and septage is quite less as compared to sewage sludge and coal. Hence, faecal sludge alone cannot act as a fuel in the furnaces. It is better to have co-combustion with coal or different fuels such as wood etc. in cement or brick kilns. However, it needs to be noted that incineration is only possible when the dewatered sludge is dried with solid content of up to 60% or more. The financial viability of thermal drying can be understood by checking if the cost of drying the sludge or combustion of sludge is less than the financial gains envisioned from the extracted heat in the process.

Fluidised bed incinerator

It consists of a single-chamber cylindrical vessel with refractory walls. The organic particles of the dewatered sludge remain in contact with the fluidised sand bed until complete combustion. The present trend favours fluidised bed incinerator over multiple chamber furnaces, due to smaller operational costs and better air quality released through its chimney. Operation under autogenous conditions at temperatures above 815°C assures complete destruction of volatile organic compounds. This is also found to be a cost-effective option. Dewatering equipment nowadays is able to feed cakes with more than 35% total solids to incinerators, making autogenous combustion operation feasible.

Figure 62: Fluidised bed incinerator

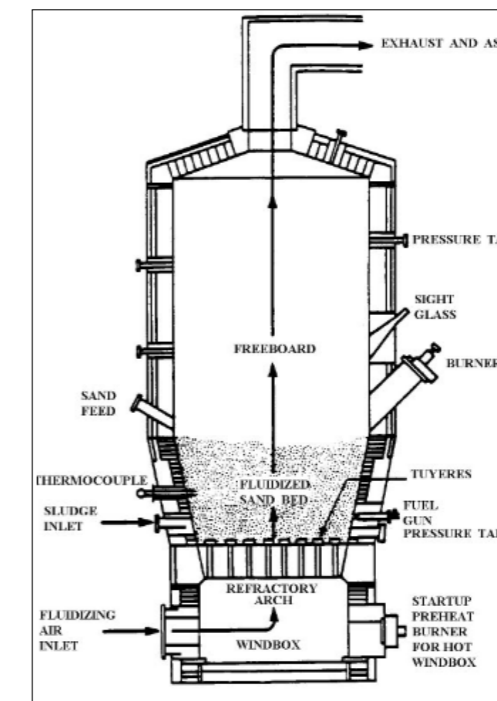

Source: US EPA, 42 Vol 2 - Sludge Incinerator

Pyrolysis

Pyrolysis is an intermediate stage in the combustion process. In an oxygen deficient environment and at a temperature within the range 200 to 500°C, the pyrolysis process takes place. The organic molecules in the sludge are chemically altered to yield carbon-based products such as biochar, oils and gases. These products can then be used as fuels for completing the combustion process.

Dry pyrolysis refers to the process which takes place in a dry environment. The sludge to be pyrolysed, needs to be dried for achieving a solid content of more than 60%. This is required to avoid a sudden drop in temperature of the pyrolyser. The figure below shows the complete process from drying to pyrolysis in a skid mounted unit. Dewatered sludge falls on the conveyer belt and is exposed to hot gases coming from the pyrolysis process. The hot air drives away the moisture and are treated before it is released into the environment. The dried solids then fall into the pyrolyser. In the pyrolyser, the dried sludge gets converted into a product called biochar which is a form of coal. The biochar is removed from the pyrolyser using a discharge screw. Thus, it can be seen that this process does not involve any physical handling of sludge making the complete process safe for handling of the sludge.

Figure 66: Schematic diagram of pyrolizer

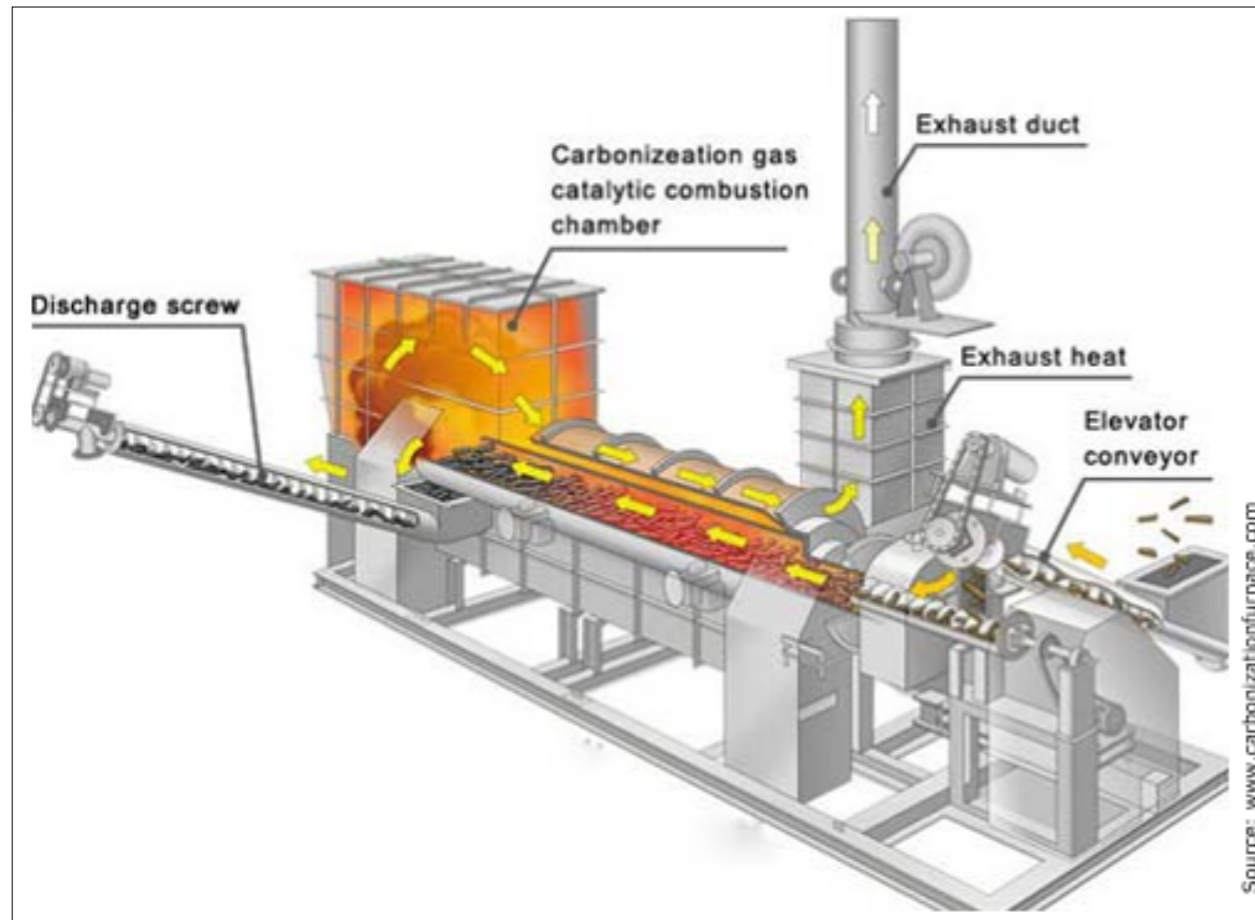

Source: King Tiger Group

Hydro-thermal carbonisation

Hydro-thermal carbonisation or wet pyrolysis is also one way of tackling dewatered sludge. In this process, the dewatered sludge is subjected to high pressure and temperature by introducing steam in the reactor. Due to the control parameters, the water reaches its critical stage and chemically alters organic carbon present in the solids. Although this process is termed as ineffective carbonisation, the end product is free from pathogens and rich in nutrients. The end product of this process is called hydrochar and it can be used as soil supplement to improve its fertility.

Figure 67: Hydro-thermal carbonisation



Source: G8 International Trading Ltd.

10.5 Notes for trainer

Various videos and case studies provided will help more in knowing about the disinfection of sludge, solar and thermal drying, biosolids and incinerators.

10.6 Bibliography

Kevin Tayler (2018); Faecal sludge & septage treatment- A guide for low- and middle-income countries

Strande, L.; Ronteltap, M.; Brdjanovic, D. (2014): Faecal Sludge Management (FSM): Systems Approach for Implementation and Operation. London: IWA Publishing

Download our latest reports, research briefs
and training modules at:

scbp.niua.org

About NIUA

NIUA is a premier national institute for research, capacity building and dissemination of knowledge in the urban sector, including sanitation. Established in 1976, it is the apex research body for the Ministry of Housing and Urban Affairs (MoHUA), Government of India. NIUA is also the strategic partner of the MoHUA in capacity building for providing single window services to the MoHUA/states/ULBs.

About SCBP

The Sanitation Capacity Building Platform (SCBP) is an initiative of the National Institute of Urban Affairs (NIUA) to address urban sanitation challenges in India. SCBP, supported by Bill & Melinda Gates Foundation (BMGF) is an organic and growing collaboration of credible national and international organisations, universities, training centres, resource centres, non-governmental organisations, academia, consultants and experts. SCBP supports national urban sanitation missions, states and ULBs, by developing and sourcing the best capacity building, policy guidance, technological, institutional, financial and behaviour change advise for FSSM. SCBP provides a unique opportunity for:

- Sharing and cross learning among the partner organisations, to pool in their knowledge resources on all aspects of urban sanitation capacity building;
- Developing training modules, learning and advocacy material including key messages and content, assessment reports and collating knowledge products on FSSM. Through its website (scbp.niua.org), SCBP is striving to create a resource centre on learning and advocacy materials, relevant government reports, policy documents and case studies;
- Dissemination of FSSM research, advocacy and outreach to State governments and ULBs.

Its strength is its ability to bring together partners to contribute towards developing state sanitation policy, training of trainers and training content development, technical and social assessments, training programme delivery, research and documentation.



National Institute of Urban Affairs

National Institute of Urban Affairs

1st Floor, Core 4B, India Habitat Centre, Lodhi Road, New Delhi - 110003

Phone: 011-24617517, 24617543, 24617595, Fax: 011-24617513

E-mail: niua@niua.org • Website: www.niua.org, scbp.niua.org

CO-TREATMENT OF FAECAL SLUDGE AND SEPTAGE WITH SEWAGE IN SEWAGE TREATMENT PLANT

PART B: LEARNING NOTES